

STRAIGHT TRUNKING

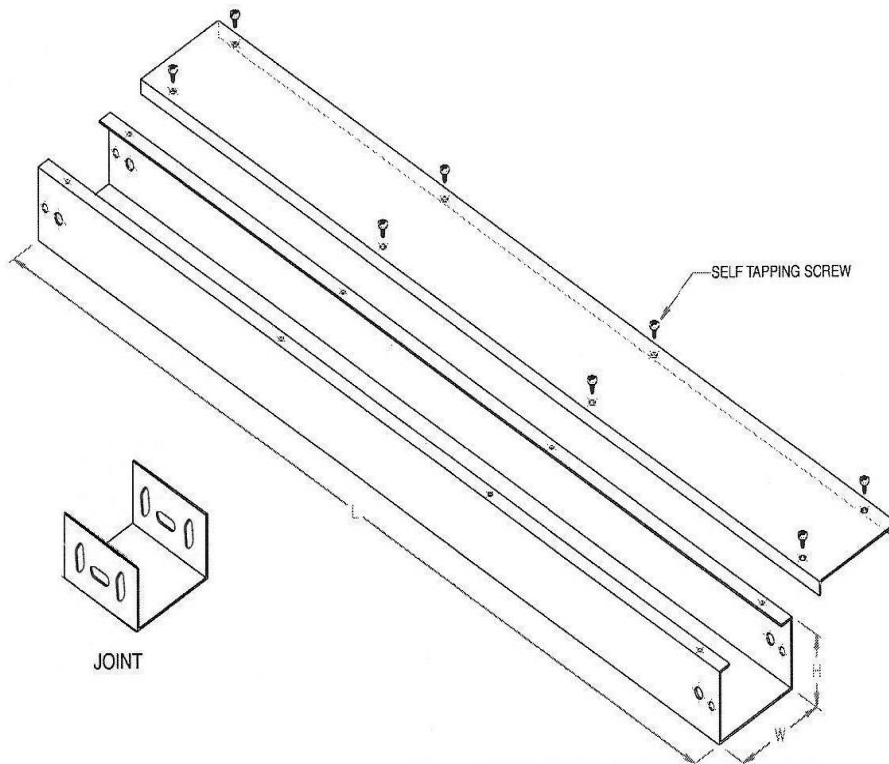

PRODUCT LIST			
HEIGHT (H)	WIDTH (W)	LENGTH (L)	THICKNESS (T)
25	50	2440	0.4/0.6/0.8
50	50	2440	0.4/0.6/0.8
50	75	2440	0.4/0.6/0.8
50	100	2440	0.4/0.6/0.8
50	150	2440	0.4/0.6/0.8
75	75	2440	0.4/0.6/0.8
75	100	2440	0.4/0.6/0.8
75	150	2440	0.4/0.6/0.8
100	100	2440	0.6/0.8
100	150	2440	0.6/0.8

PRODUCT LIST			
HEIGHT (H)	WIDTH (W)	LENGTH (L)	THICKNESS (T)
25	50	2440	1.0/1.5
50	50	2440	1.0/1.5
50	75	2440	1.0/1.5
50	100	2440	1.0/1.5
50	50	2440	1.0/1.5
75	75	2440	1.0/1.5
75	100	2440	1.0/1.5
75	150	2440	1.0/1.5
100	100	2440	1.0/1.5
100	150	2440	1.0/1.5
100	200	2440	1.0/1.5
100	250	2440	1.0/1.5
100	300	2440	1.0/1.5

* All units in mm

MATERIALS

- 1 Hot / Cold-Rolled Steel
- 2 Electro-Galvanized steel to BS 1449 Part 1 : 1983
- 3 Pre-Galvanized Steel
- 4 Stainless Steel AISI 304, 316 or 316L
- 5 Superdyma

FINISHING

- 1 Epoxy Powder Coated
- 2 Hot-Dipped Galvanizing (BS:EN:ISO1461 (1999), BS 729)
- 3 Hot-Dipped Galvanising and Epoxy Powder Coated

CABLE TRUNKING & ACCESSORIES

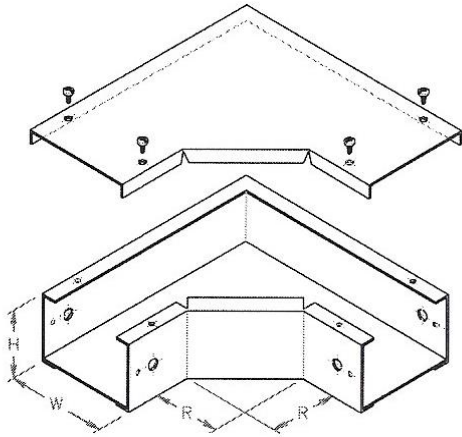

90 DEG. HORIZONTAL FLAT ELBOW

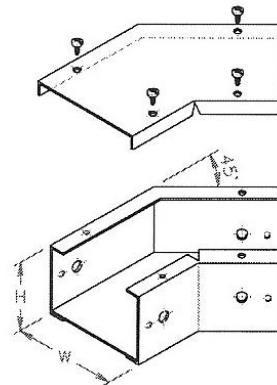

45 DEG. HORIZONTAL FLAT ELBOW

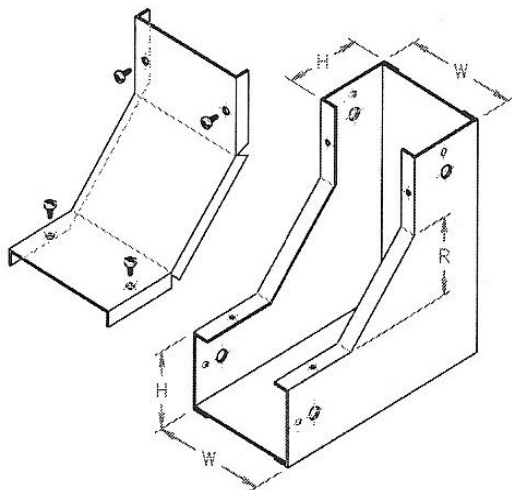

90 DEG. VERTICAL INSIDRISER

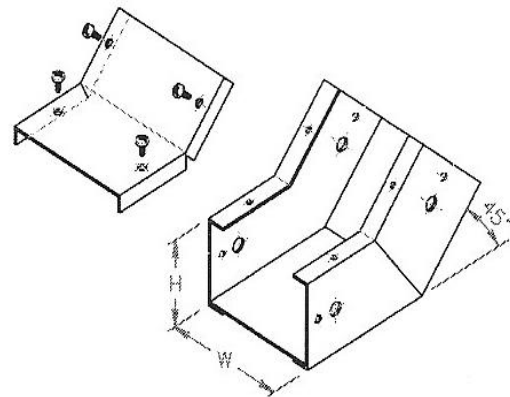

45 DEG. VERTICAL INSIDRISER

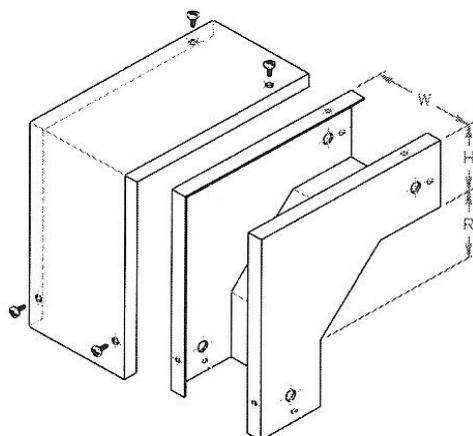

90 DEG. VERTICAL OUTSIDRISER

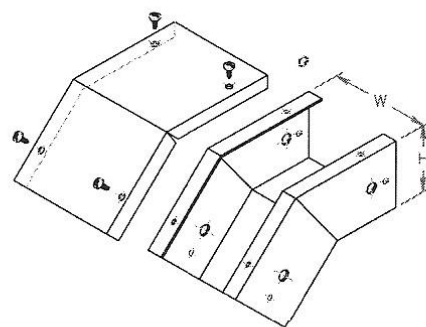

45 DEG. VERTICAL OUTSIDRISER

CABLE TRUNKING & ACCESSORIES

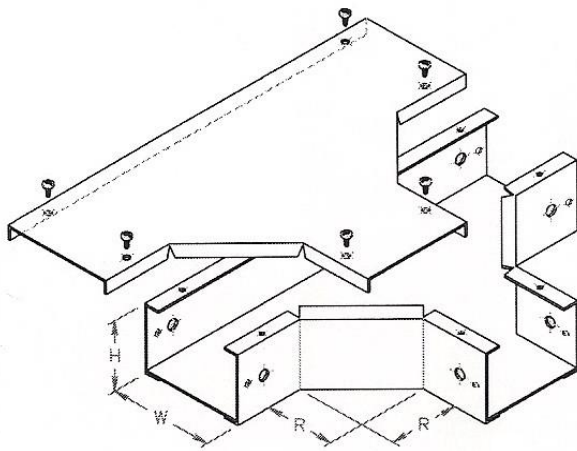

HORIZONTAL EQUAL TEE

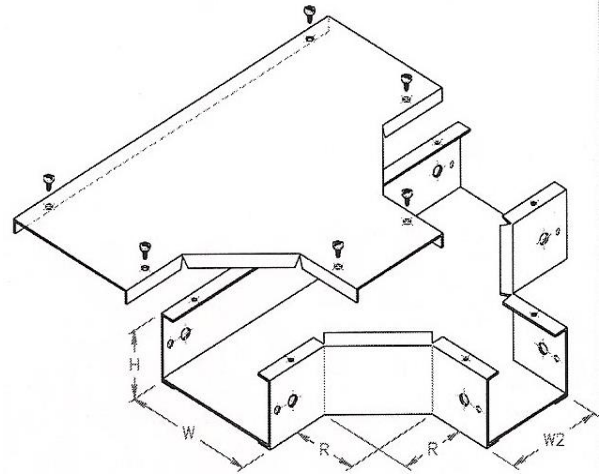

HORIZONTAL UNEQUAL TEE

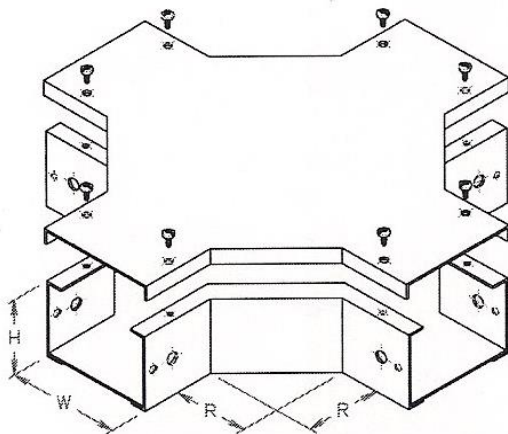

HORIZONTAL EQUAL CROSS

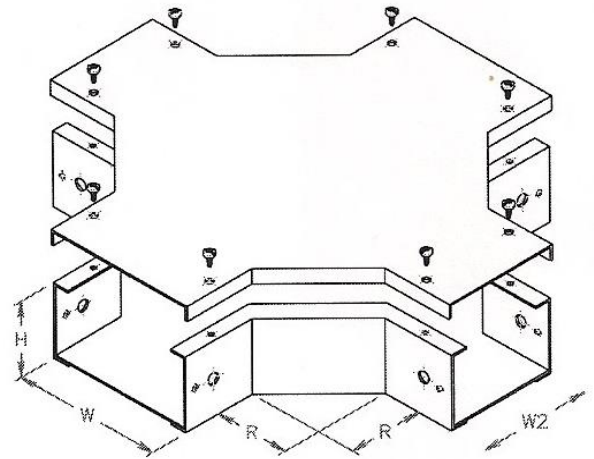

HORIZONTAL UNEQUAL CROSS

PRODUCT LIST			
HEIGHT (H)	WIDTH (W)	RADIUS (R)	THICKNESS (T)
25	50	50	0.6 / 0.8
50	50	50	0.6 / 0.8
50	75	50	0.6 / 0.8
50	100	50	0.6 / 0.8
50	150	50	0.6 / 0.8
75	75	50	0.6 / 0.8
75	100	50	0.6 / 0.8
75	150	50	0.6 / 0.8
100	100	50	0.8
100	150	50	0.8

PRODUCT LIST			
HEIGHT (H)	WIDTH (W)	RADIUS (R)	THICKNESS (T)
25	50	50	1.0 / 1.5
50	50	50	1.0 / 1.5
50	75	50	1.0 / 1.5
50	100	50	1.0 / 1.5
50	150	50	1.0 / 1.5
75	75	50	1.0 / 1.5
75	100	50	1.0 / 1.5
75	150	50	1.0 / 1.5
100	100	50	1.0 / 1.5
100	150	50	1.0 / 1.5
100	200	50	1.0 / 1.5
100	250	50	1.0 / 1.5
100	300	50	1.0 / 1.5

* All units in mm

NOTE: Other sizes are available upon request

CABLE TRUNKING & ACCESSORIES

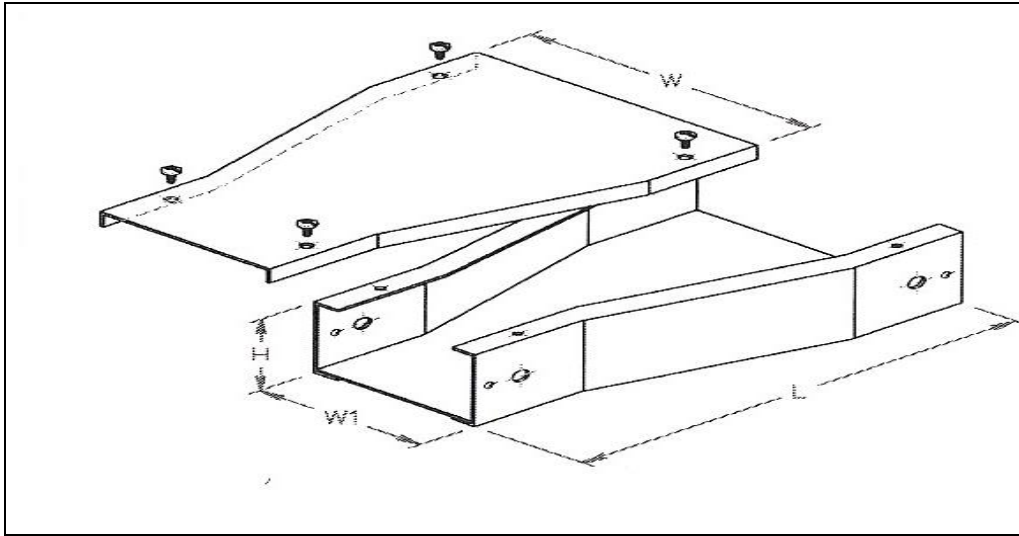

STRAIGHT REDUCER

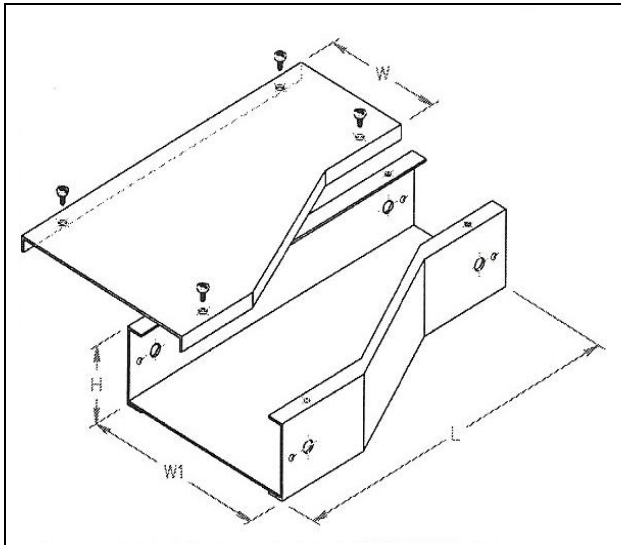

LEFT-HAND REDUCER

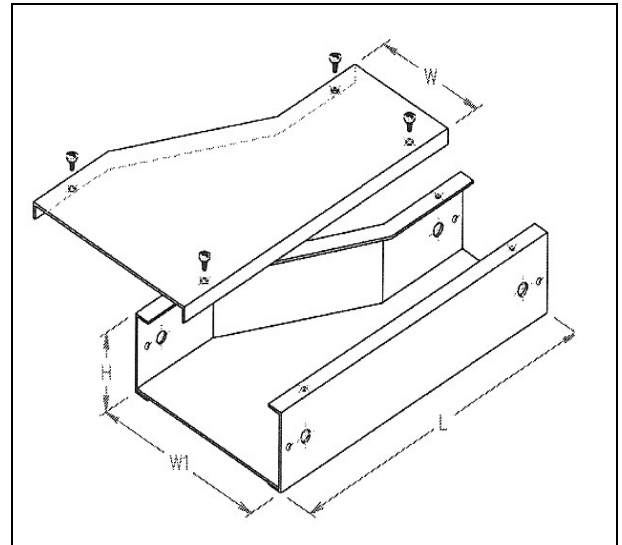

RIGHT-HAND REDUCER

PRODUCT LIST

WIDTH (W)	HEIGHT (H)	WIDTH (W1)	LENGTH (L)	THICKNESS (T)
150	25	50	300	0.8 / 1.5
150	50	50	300	0.8 / 1.5
200	50	50	300	0.8 / 1.5
200	75	50	300	0.8 / 1.5
200	50	75	300	1.0 / 1.5
200	100	75	300	1.0 / 1.5
250	50	75	300	1.0 / 1.5
250	100	75	300	1.0 / 1.5
250	100	100	300	1.0 / 1.5
300	100	100	300	1.0 / 1.5
300	100	150	300	1.0 / 1.5
450	100	200	300	1.5

* All units in mm

NOTE: Other sizes are available upon request

CABLE TRUNKING & COMPONENTS ASSEMBLY GUIDE

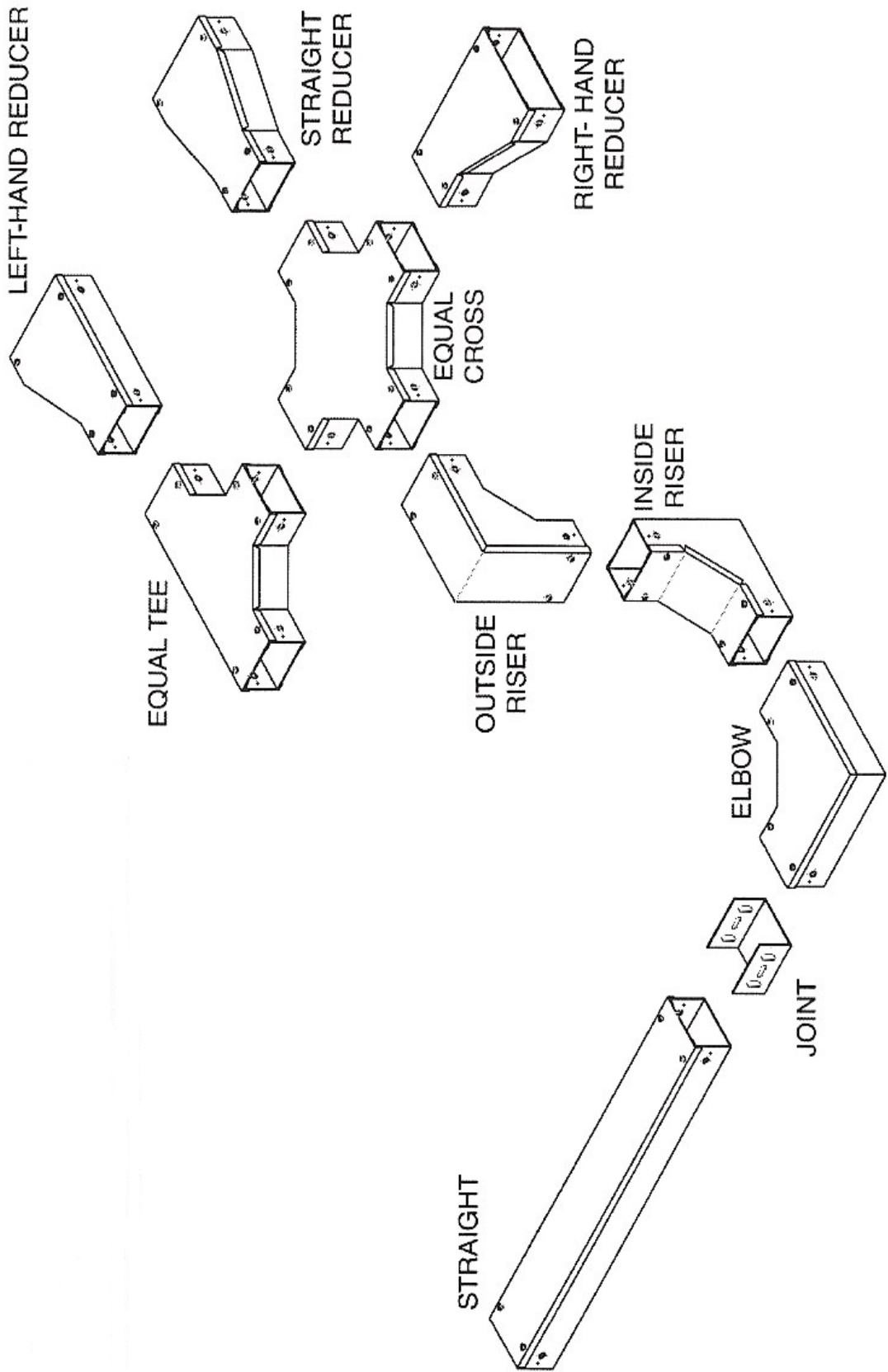

* A PREFABRICATED METAL STRUCTURE CONSISTING OF ONE PIECE BOX CHANNEL SECTION

CABLE TRUNKING & ACCESSORIES