

STRAIGHT PERFORATED TRAY

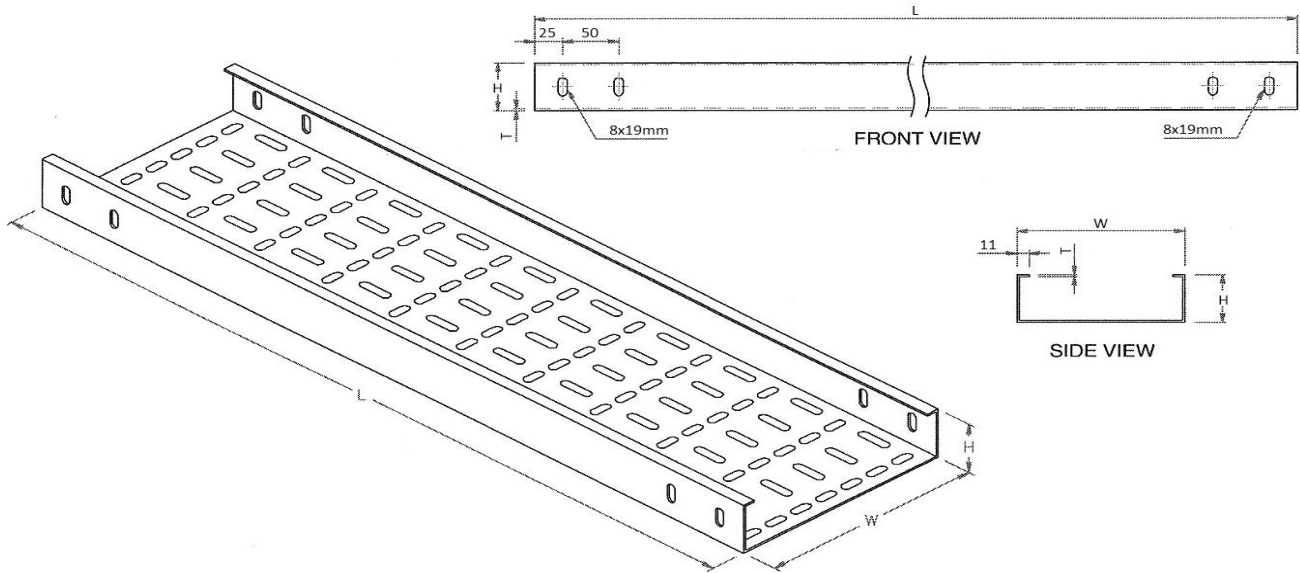

RETURNED EDGE TYPE

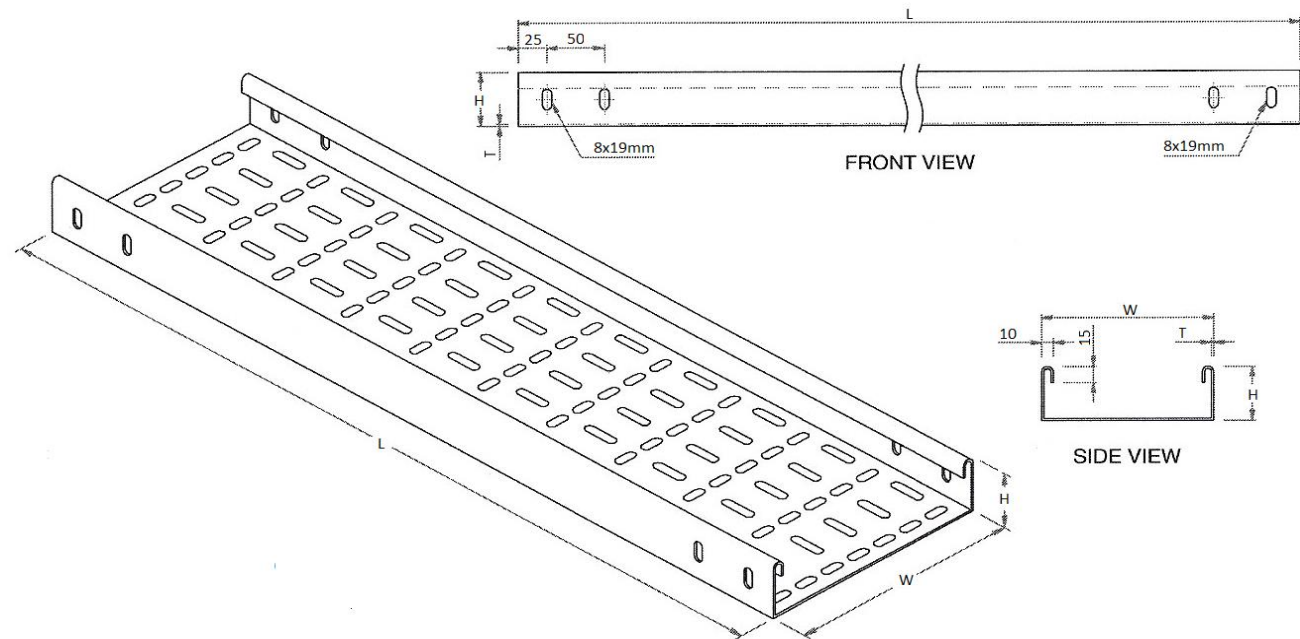

RETURNED FLANGE TYPE

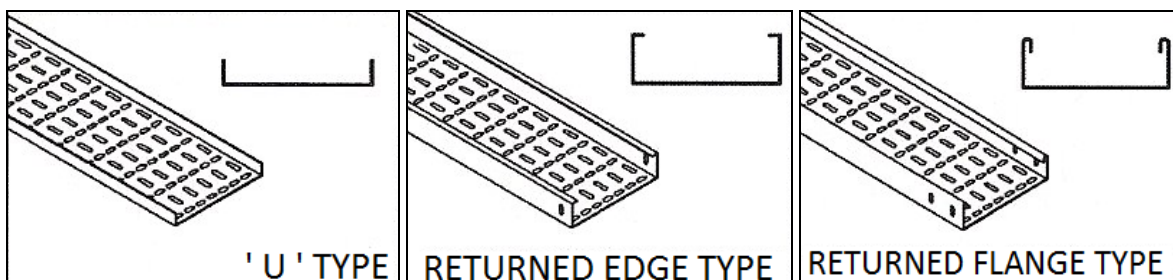

NOTE: Other sizes are available upon request

CABLE TRAY & ACCESSORIES

STRAIGHT CABLE TRAY STANDARD LIST

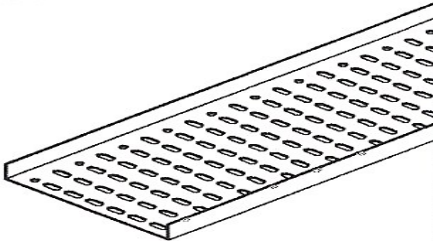
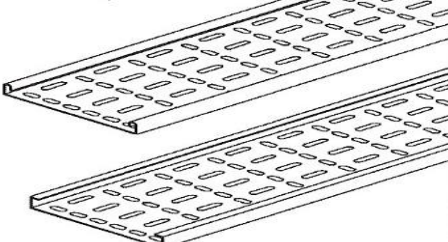
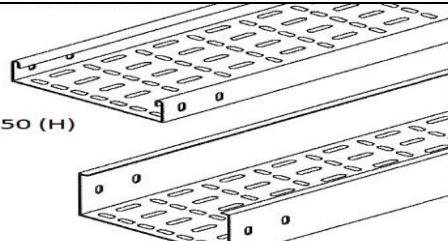
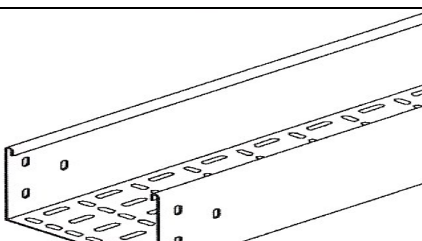
SIZE				REMARKS	
WIDTH (W)	HEIGHT (H)	LENGTH (L)	THICKNESS (T)		
50	15	2440	1.0	 15 (H)	
100	15				
150	15				
200	20				
300	25	3000	1.2		
400	25				
500	25				
600	30				
150	25	2440	1.0		 25 (H)
200	25				
300	25				
450	25				
600	25	3000	1.5		
750	25				
900	25				
1000	25				
200	50/100	2440	1.0	 50 (H)	
300	50/100				
400	50/100				
450	50/100				
600	50/100	3000	1.5		
750	50/100				
900	50/100				
1000	50/100				
200	150	2440	1.5		 150 (H)
300	150				
400	150				
450	150				
600	150	3000	2.0		
750	150				
900	150				
1000	150				
			3.0		

*All units in mm

MATERIALS

- 1 Hot / Cold-Rolled Steel
- 2 Electro-Galvanized steel to BS 1449 Part 1 : 1983
- 3 Pre-Galvanized Steel
- 4 Stainless Steel AISI 304, 316 or 316L
- 5 Aluminium AA1100, 5052-H32, 6063-75
- 6 Superdyma

FINISHING

- 1 Epoxy Powder Coated
- 2 Hot-Dipped Galvanizing
(BS:EN:ISO1461 (1999), BS 729)
- 3 Hot-Dipped Galvanizing and Epoxy
Powder Coated
- 4 Anodized (for Aluminium Only)

NOTE: Other sizes are available upon request

90 DEG. HORIZONTAL FLAT BEND (ELBOW)

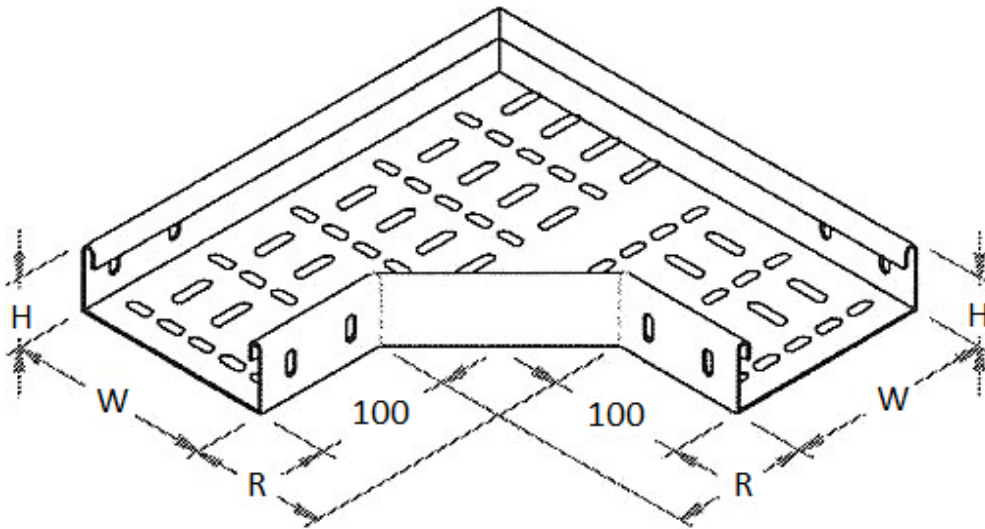

90 DEG. HORIZONTAL FLAT BEND WITH CURVE RADIUS (R)

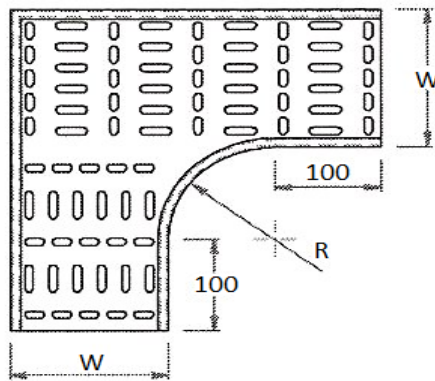

TOP VIEW

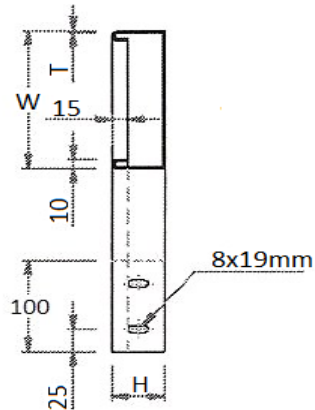

SIDE VIEW

90 DEG. HORIZONTAL FLAT BEND WITH STRAIGHT RADIUS (R)

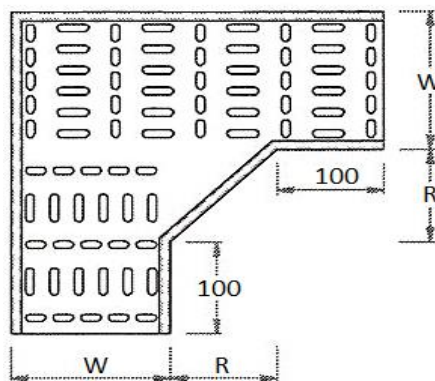

TOP VIEW

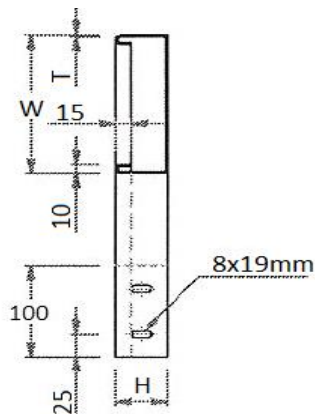

SIDE VIEW

CABLE TRAY & ACCESSORIES

45 DEG. HORIZONTAL FLAT BEND WITH CURVE RADIUS (R)

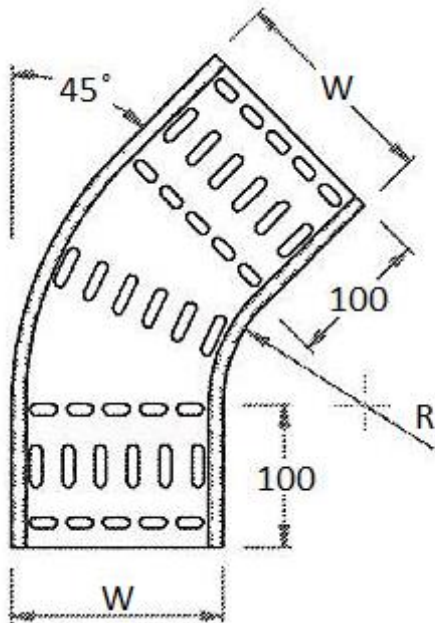

TOP VIEW

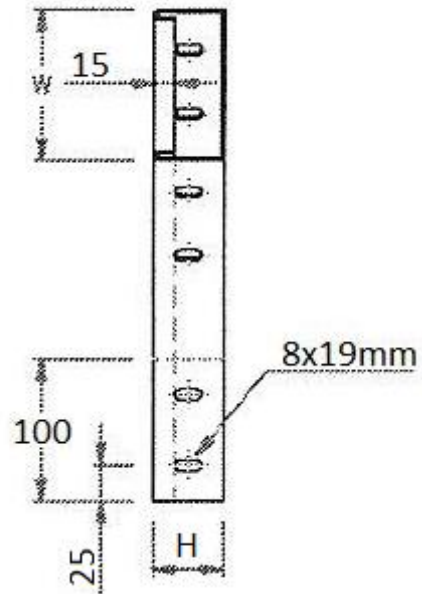

SIDE VIEW

45 DEG. HORIZONTAL FLAT BEND WITH STRAIGHT RADIUS (R)

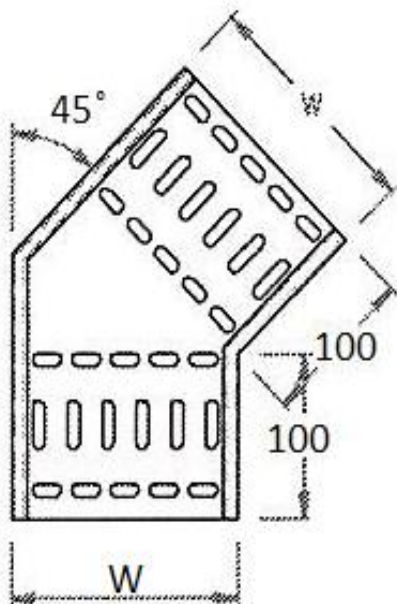

TOP VIEW

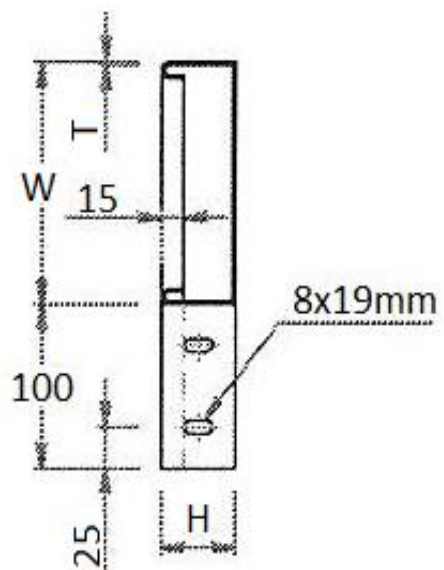

SIDE VIEW

CABLE TRAY & ACCESSORIES

BEND CABLE TRAY STANDARD LIST

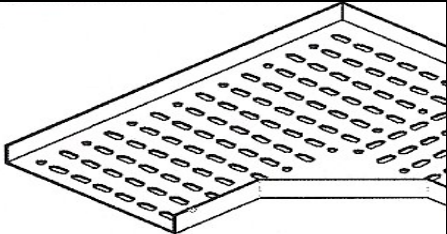
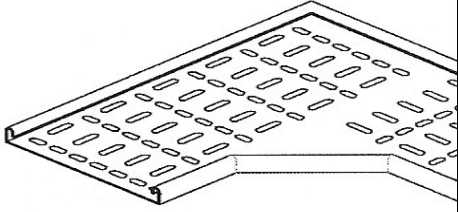
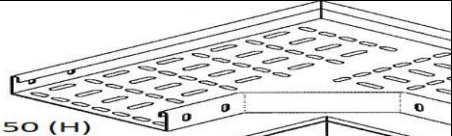
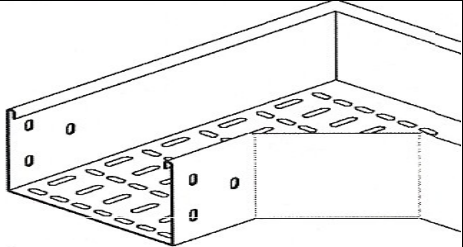
SIZE				REMARKS
WIDTH (W)	HEIGHT (H)	RADIUS (R)	THICKNESS (T)	
50	15	50 100 200	1.0 1.2 1.5 2.0	 15 (H)
75	15			
100	15			
150	15			
200	20			
300	25			
400	25			
500	30			
50	25	50 100 200 300	1.0 1.2 1.5 2.0	 25 (H)
75	25			
100	25			
200	25			
300	25			
400	25			
500	25			
600	25			
50	50	100 200 300 450 600	1.0 1.2 1.5 2.0	 50 (H)
75	50			
100	50/100			
200	50/100			
300	50/100			
400	50/100			
500	50/100			
600	50/100			
125	125	250 300 450 600	1.5 2.0 2.5 3.0	 150 (H)
150	125/150			
200	125/150			
300	125/150			
400	125/150			
500	125/150			
600	125/150			
700	125/150			

*All units in mm

MATERIALS

- Hot / Cold-Rolled Steel
- Electro-Galvanized steel to BS 1449 Part 1 : 1983
- Pre-Galvanized Steel
- Stainless Steel AISI 304, 316 or 316L
- Aluminium AA1100, 5052-H32, 6063-75
- Superdyma

FINISHING

- Epoxy Powder Coated
- Hot-Dipped Galvanizing
(BS:EN:ISO1461 (1999), BS 729)
- Hot-Dipped Galvanizing and Epoxy Powder Coated
- Anodized (for Aluminium Only)

NOTE: Other sizes are available upon request

HORIZONTAL EQUAL TEE

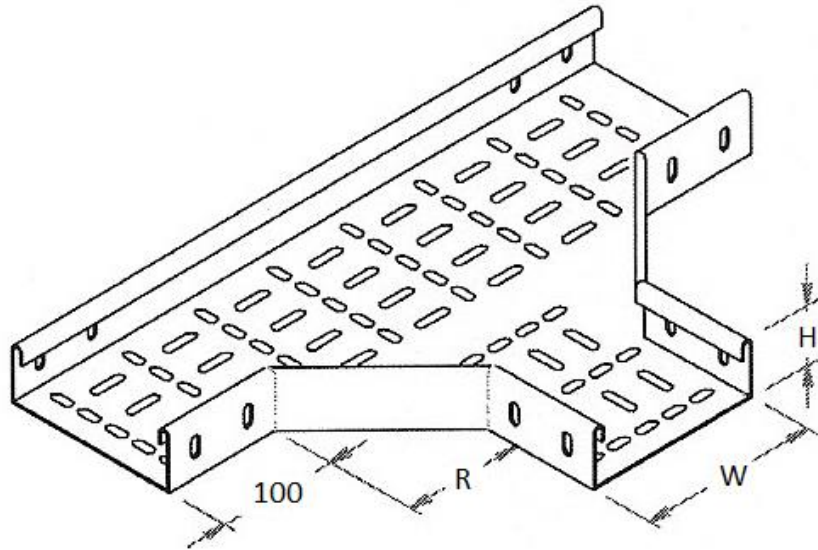

HORIZONTAL EQUAL TEE
RETURNED FLANGE WITH STRAIGHT RADIUS

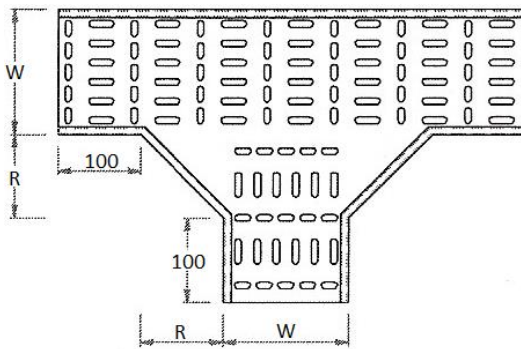

TOP VIEW

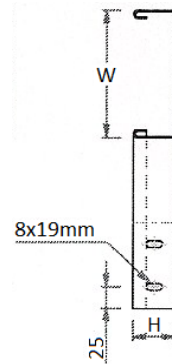

SIDE VIEW

HORIZONTAL EQUAL TEE
RETURNED FLANGE WITH CURVE RADIUS

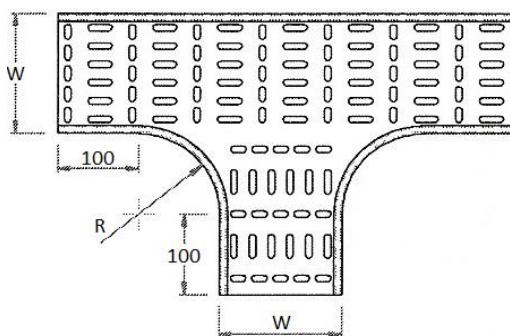

TOP VIEW

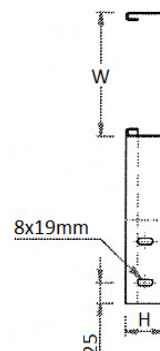

SIDE VIEW

HORIZONTAL UNEQUAL TEE

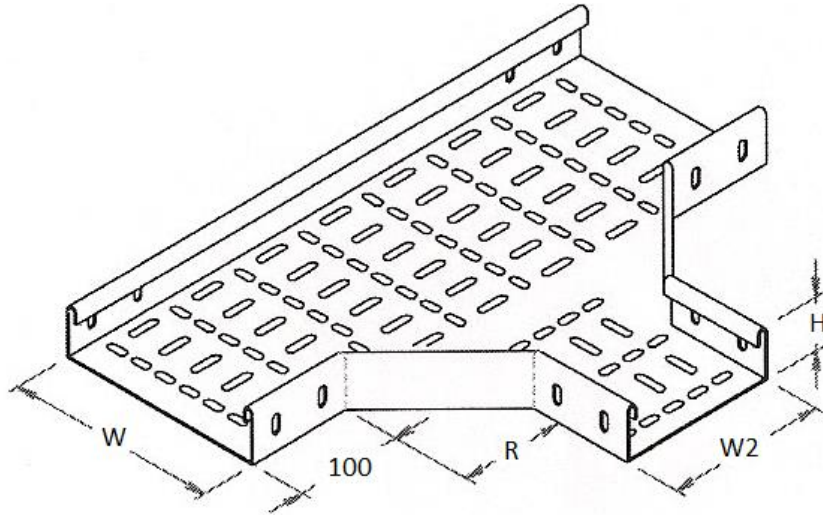

HORIZONTAL UNEQUAL TEE
RETURNED FLANGE WITH STRAIGHT RADIUS

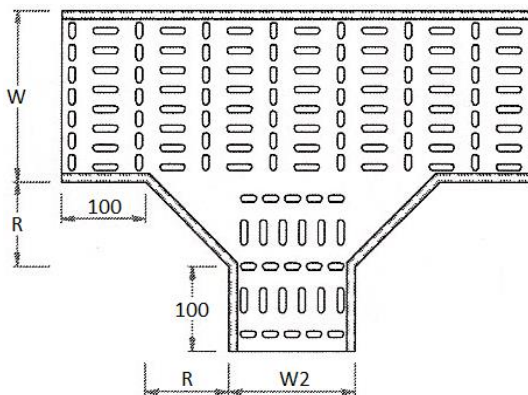

TOP VIEW

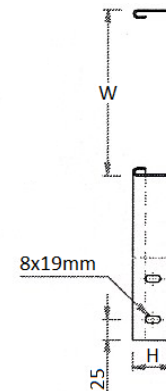

SIDE VIEW

HORIZONTAL UNEQUAL TEE
RETURNED FLANGE WITH CURVE RADIUS

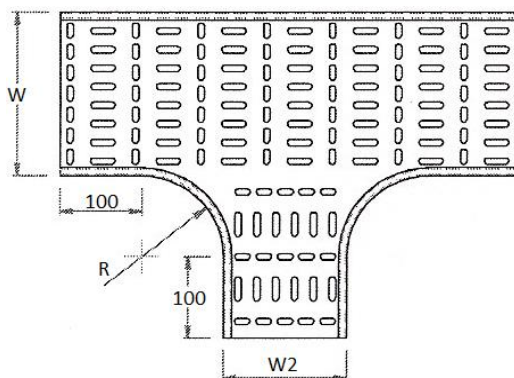

TOP VIEW

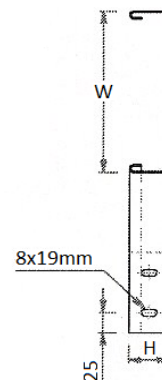

SIDE VIEW

CABLE TRAY & ACCESSORIES

TEE HORIZONTAL UNEQUAL TEE STANDARD LIST

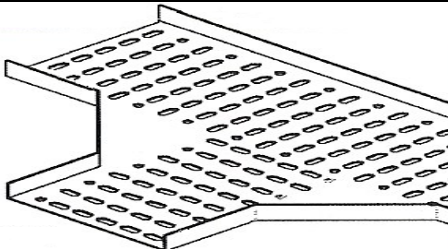
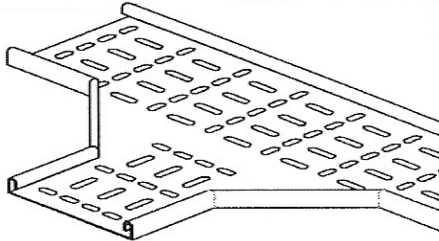
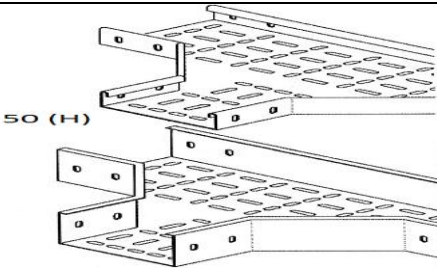
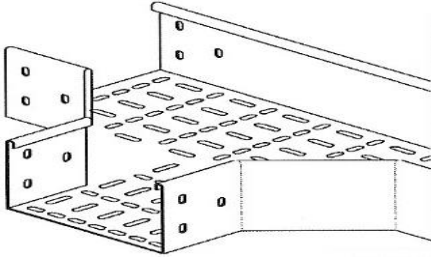
SIZE				REMARKS
WIDTH (W)	HEIGHT (H)	RADIUS (R)	THICKNESS (T)	
50	15	50 100 200	1.0 1.2 1.5 2.0	 15 (H)
75	15			
100	15			
150	15			
200	20			
300	25			
400	25			
500	30			
50	25	50 100 200 300	1.0 1.2 1.5 2.0	 25 (H)
75	25			
100	25			
200	25			
300	25			
400	25			
500	25			
600	25			
50	50	100 200 300 450 600	1.0 1.2 1.5 2.0	 50 (H)
75	50			
100	50/100			
200	50/100			
300	50/100			
400	50/100			
500	50/100			
600	50/100			
125	125	200 300 450 600	1.5 2.0 2.5 3.0	 150 (H)
150	125/150			
200	125/150			
300	125/150			
400	125/150			
500	125/150			
600	125/150			
700	125/150			

*All units in mm

MATERIALS

- Hot / Cold-Rolled Steel
- Electro-Galvanized steel to BS 1449 Part 1 : 1983
- Pre-Galvanized Steel
- Stainless Steel AISI 304, 316 or 316L
- Aluminium AA1100 or 5052-H32, 6013-75
- Superdyma

FINISHING

- Epoxy Powder Coated
- Hot-Dipped Galvanizing
(BS:EN:ISO1461 (1999), BS 729)
- Hot-Dipped Galvanizing and Epoxy Powder Coated
- Anodized (for Aluminium Only)

NOTE: Other sizes are available upon request

HORIZONTAL EQUAL CROSS

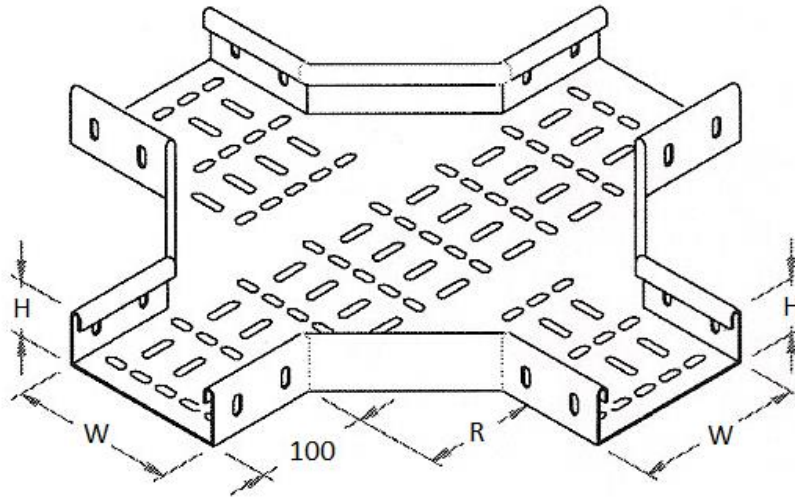

HORIZONTAL EQUAL CROSS
RETURNED FLANGE WITH STRAIGHT RADIUS

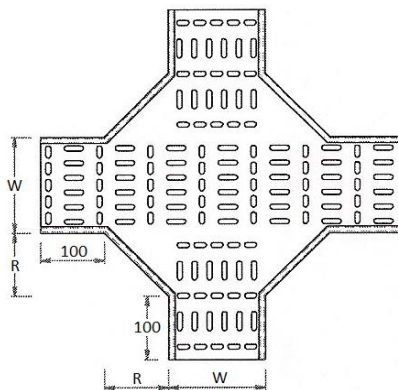

TOP VIEW



SIDE VIEW

HORIZONTAL EQUAL CROSS
RETURNED FLANGE WITH CURVE RADIUS

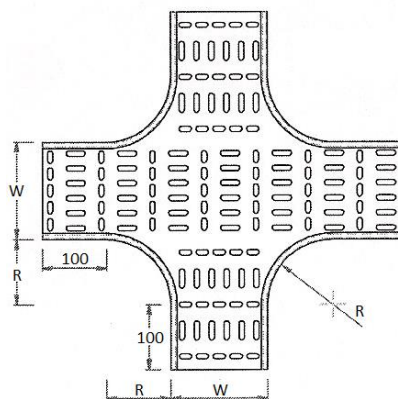

TOP VIEW



SIDE VIEW

HORIZONTAL UNEQUAL CROSS

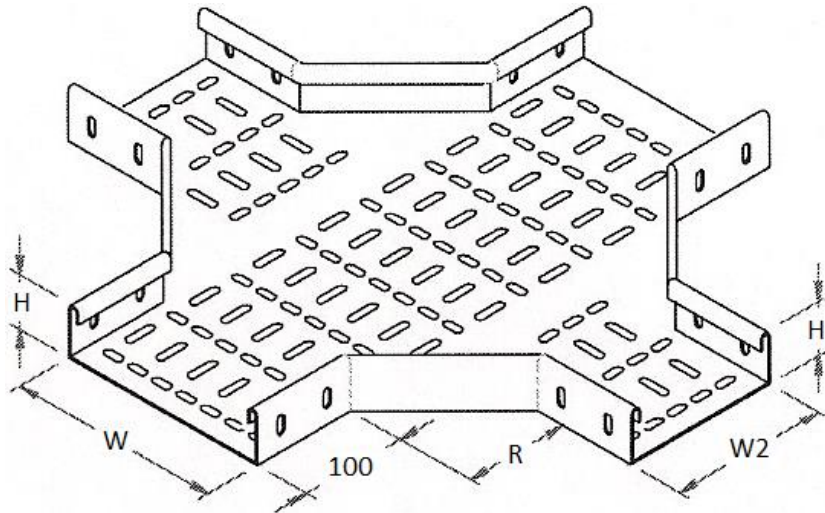

HORIZONTAL UNEQUAL CROSS
RETURNED FLANGE WITH STRAIGHT RADIUS

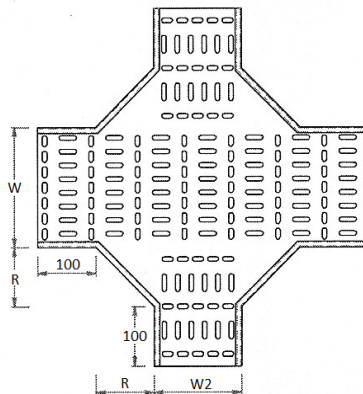

TOP VIEW

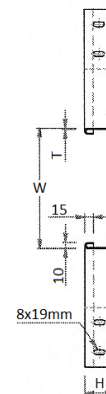

SIDE VIEW

HORIZONTAL UNEQUAL CROSS
RETURNED FLANGE WITH CURVE RADIUS

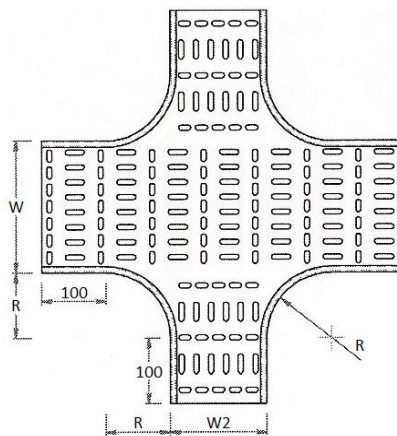

TOP VIEW



SIDE VIEW

CABLE TRAY & ACCESSORIES

CROSS CABLE TRAY STANDARD LIST

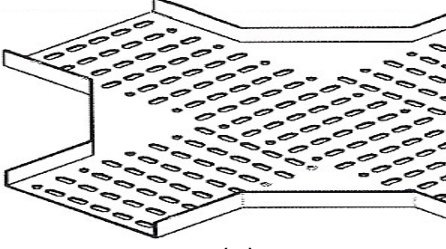
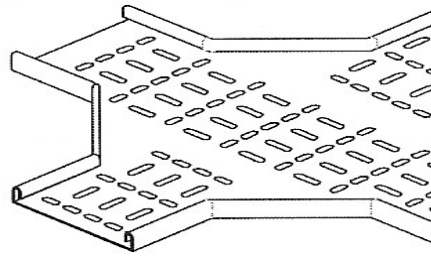
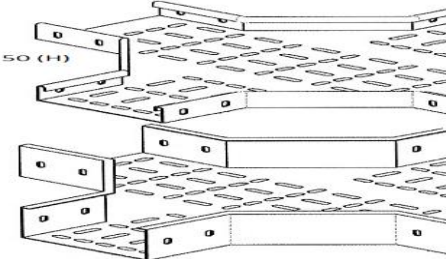
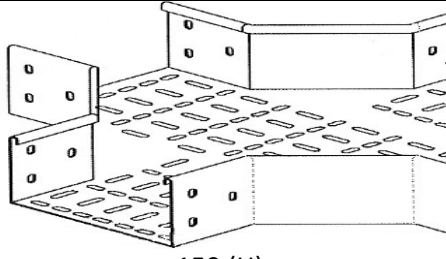
SIZE				REMARKS
WIDTH (W)	HEIGHT (H)	RADIUS (R)	THICKNESS (T)	
50	15	50 100 200	1.0 1.2 1.5 2.0	 15 (H)
75	15			
100	15			
150	15			
200	20			
300	25			
400	25			
500	30			
50	25	50 100 200 300	1.0 1.2 1.5 2.0	 25 (H)
75	25			
100	25			
200	25			
300	25			
400	25			
500	25			
600	25			
50	50	100 200 300 450 600	1.0 1.2 1.5 2.0	 100 (H)
75	50			
100	50/100			
200	50/100			
300	50/100			
400	50/100			
500	50/100			
600	50/100			
125	125	200 300 450 600	1.5 2.0 2.5 3.0	 150 (H)
150	125/150			
200	125/150			
300	125/150			
400	125/150			
500	125/150			
600	125/150			
700	125/150			

*All units in mm

MATERIALS

- Hot / Cold-Rolled Steel
- Electro-Galvanized steel to BS 1449 Part 1 : 1983
- Pre-Galvanized Steel
- Stainless Steel AISI 304, 316 or 316L
- Aluminium AA1100 or 5052-H32, 6013-75
- Superdyma

FINISHING

- Epoxy Powder Coated
- Hot-Dipped Galvanizing
(BS:EN:ISO1461 (1999), BS 729)
- Hot-Dipped Galvanizing and Epoxy Powder Coated
- Anodized (for Aluminium Only)

NOTE: Other sizes are available upon request

VERTICAL INSIDE RISER

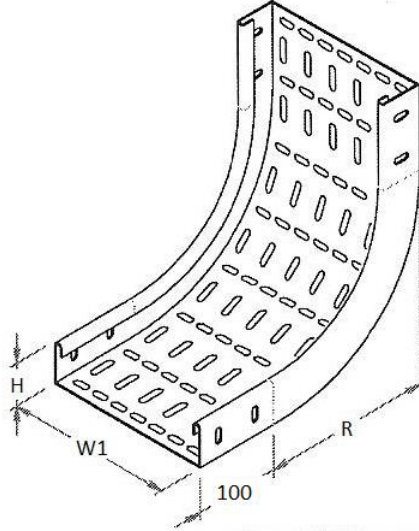

VERTICAL INSIDE RISER RETURNED FLANGE WITH CURVE RADIUS

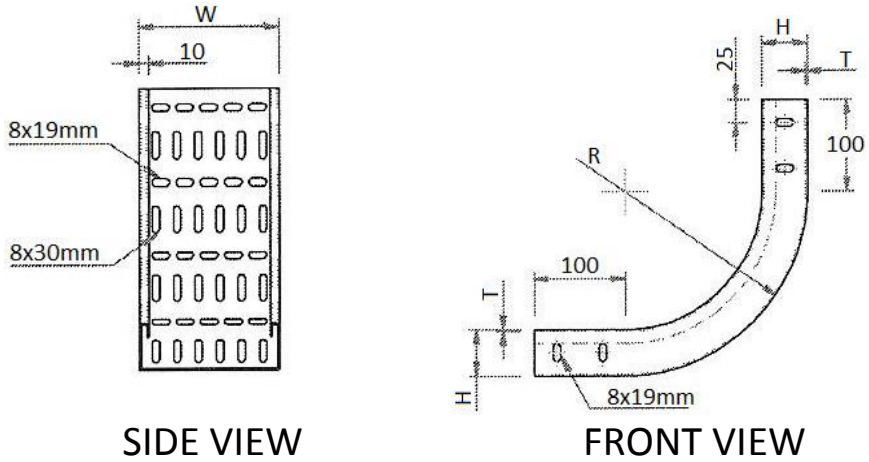

VERTICAL INSIDE RISER RETURNED FLANGE WITH STRAIGHT RADIUS

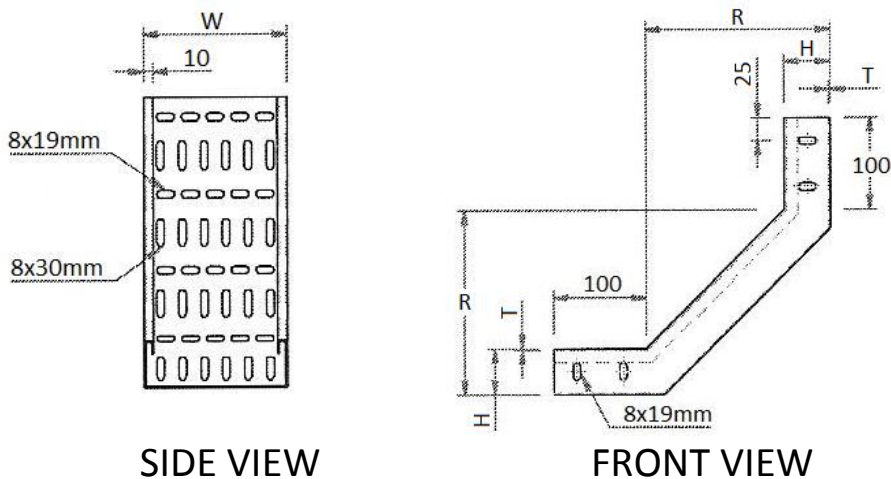

VERTICAL OUTSIDE RISER

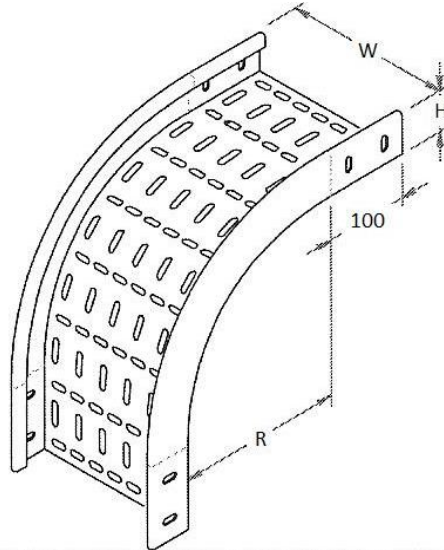

VERTICAL OUTSIDE RISER RETURNED FLANGE WITH CURVE RADIUS

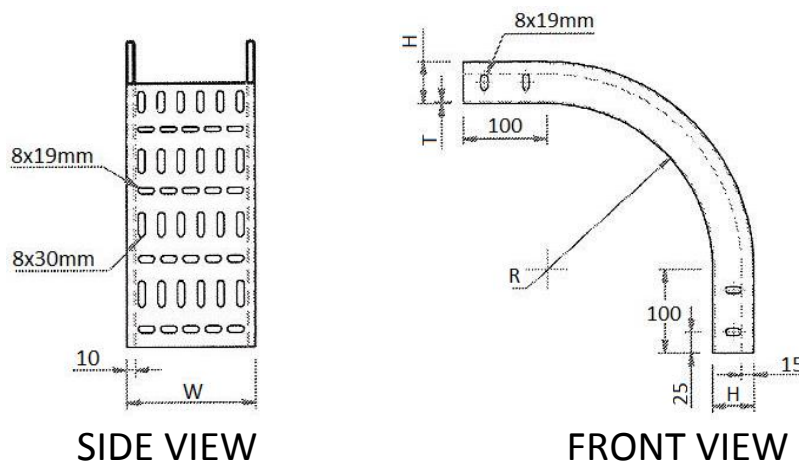

VERTICAL INSIDE RISER RETURNED FLANGE WITH STRAIGHT RADIUS

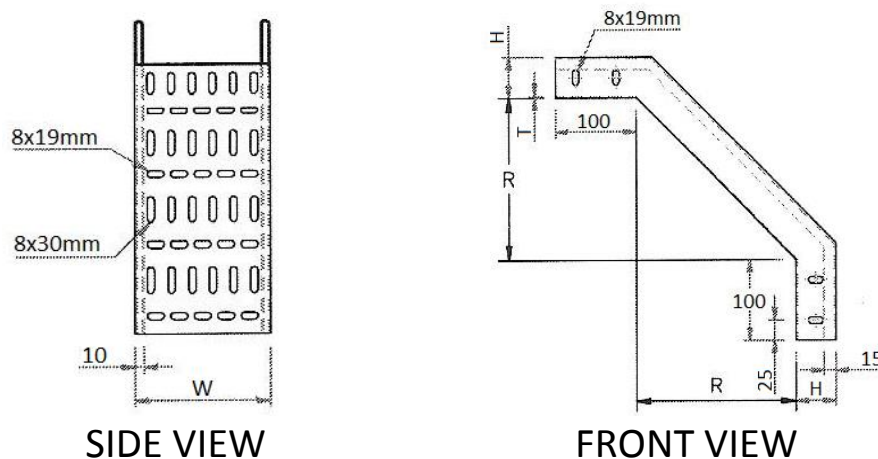

CABLE TRAY & ACCESSORIES

RISER CABLE TRAY STANDARD LIST

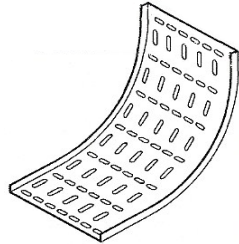
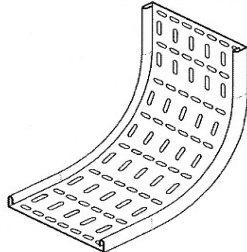
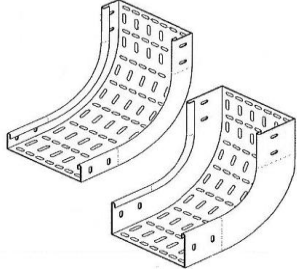
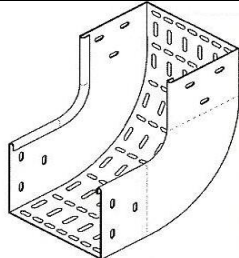
SIZE				REMARKS
WIDTH (W)	HEIGHT (H)	RADIUS (R)	THICKNESS (T)	
50	15	50 100 200	1.0 1.2 1.5 2.0	 100 (H)
75	15			
100	15			
150	15			
200	15			
300	15			
400	15			
500	15			
50	25	50 100 200 300	1.0 1.2 1.5 2.0	 125 (H)
75	25			
100	25			
200	25			
300	25			
400	25			
500	25			
600	25			
50	50	100 200 300 450 600	1.0 1.2 1.5 2.0	 150 (H)
75	50			
100	50/100			
200	50/100			
300	50/100			
400	50/100			
500	50/100			
600	50/100			
125	125	200 300 450 600	1.5 2.0 2.5 3.0	 200 (H)
150	125/150			
200	125/150			
300	125/150			
400	125/150			
500	125/150			
600	125/150			
700	125/150			

*All units in mm

MATERIALS

- Hot / Cold-Rolled Steel
- Electro-Galvanized steel to BS 1449 Part 1 : 1983
- Pre-Galvanized Steel
- Stainless Steel AISI 304, 316 or 316L
- Aluminium AA1100 or 5052-H32, 6013-75
- Superdyma

FINISHING

- Epoxy Powder Coated
- Hot-Dipped Galvanizing
(BS:EN:ISO1461 (1999), BS 729)
- Hot-Dipped Galvanizing and Epoxy Powder Coated
- Anodized (for Aluminium Only)

NOTE: Other sizes are available upon request

OFFSET REDUCER

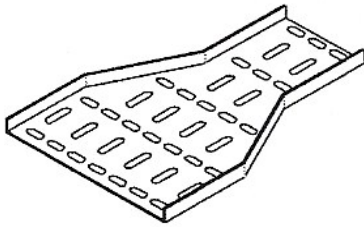

'U' TYPE

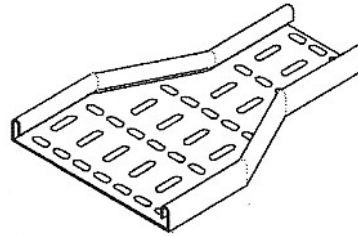

RETURNED FLANGE TYPE

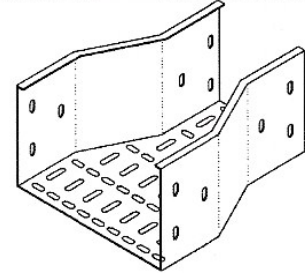

EDGE TYPE

STRAIGHT REDUCER

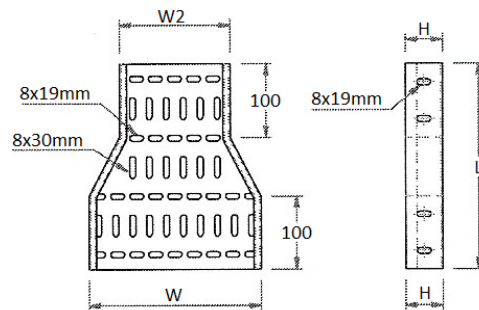
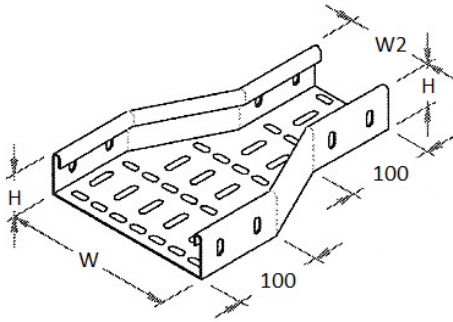

TOP VIEW

SIDE VIEW

RIGHT-HAND REDUCER

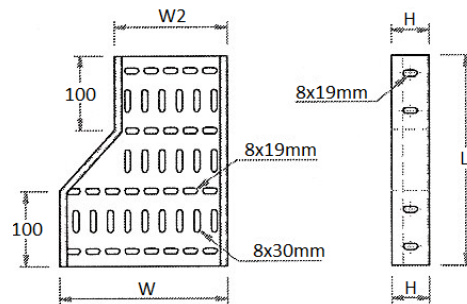
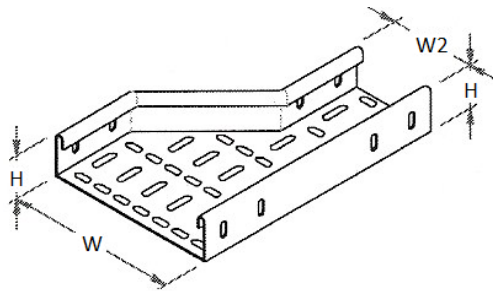

TOP VIEW

FRONT VIEW

LEFT-HAND REDUCER

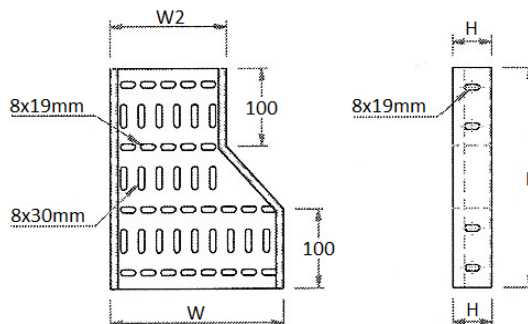
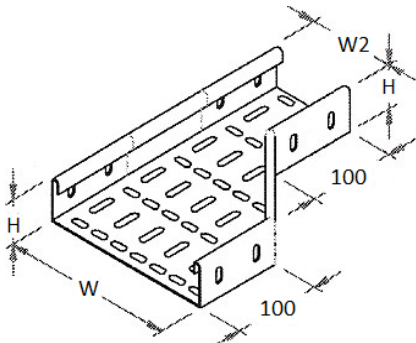

TOP VIEW

FRONT VIEW

CABLE TRAY & ACCESSORIES

REDUCER CABLE TRAY STANDARD LIST

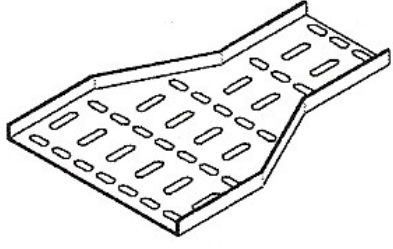
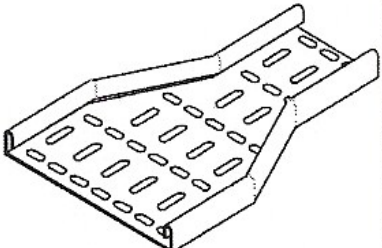
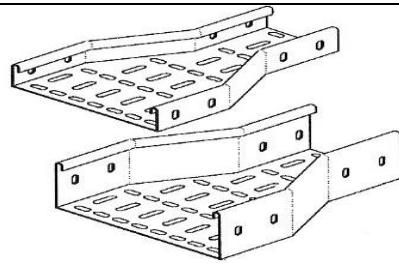
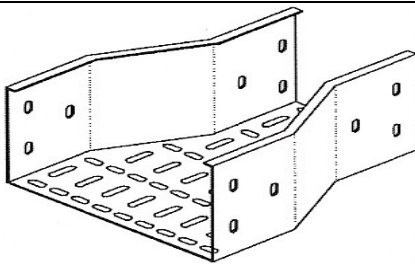
SIZE				REMARKS
WIDTH (W)	HEIGHT (H)	WIDTH (W2)	THICKNESS (T)	
150	15	50	1.0 1.2 1.5 2.0	 (H) 15
150	15	75		
100	15	100		
300	15	150		
450	15	100		
450	15	200		
600	15	200		
600	15	300		
150	25	75	1.0 1.2 1.5 2.0	 (H) 25
300	25	100		
300	25	150		
450	25	100		
450	25	200		
600	25	200		
600	25	300		
750	25	200		
150	50/100	75	1.0 1.5 2.0 2.5	 150 (H)
300	50/100	100		
450	50/100	200		
600	50/100	400		
750	50/100	300		
800	50/100	300		
900	50/100	400		
900	50/100	600		
150	125/150	200	1.5 2.0 2.5 3.0	 200 (H)
300	125/150	200		
450	125/150	300		
600	125/150	300		
750	125/150	450		
800	125/150	500		
900	125/150	450		
900	125/150	600		

*All units in mm

MATERIALS

- 1 Hot / Cold-Rolled Steel
- 2 Electro-Galvanized steel to BS 1449 Part 1 : 1983
- 3 Pre-Galvanized Steel
- 4 Stainless Steel AISI 304, 316 or 316L
- 5 Aluminium AA1100 or 5052-H32, 6013-75
- 6 Superdyma

FINISHING

- 1 Epoxy Powder Coated
- 2 Hot-Dipped Galvanizing
(BS:EN:ISO1461 (1999), BS 729)
- 3 Hot-Dipped Galvanizing and Epoxy Powder Coated
- 4 Anodized (for Aluminium Only)

NOTE: Other sizes are available upon request

STRAIGHT JOINT

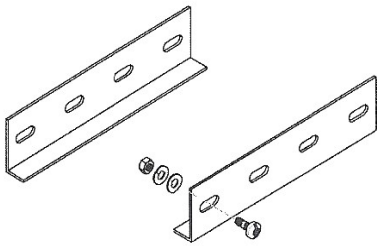
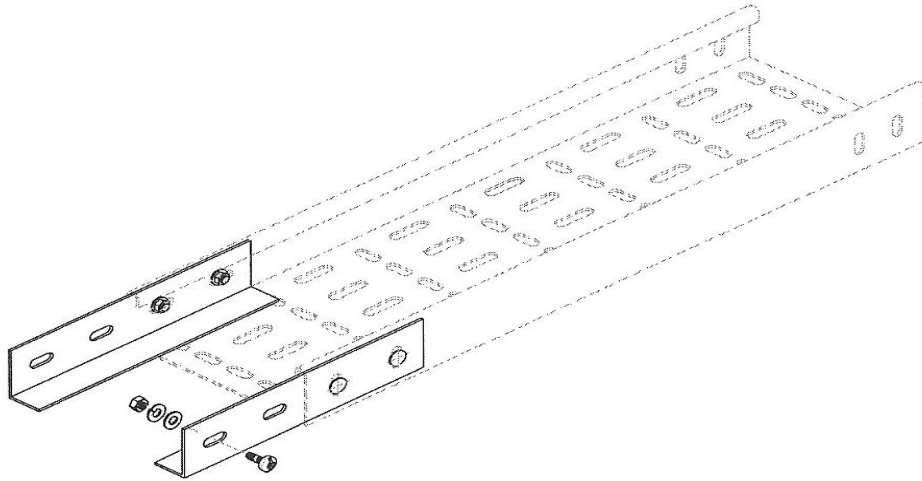

STRAIGHT JOINT -100(H)

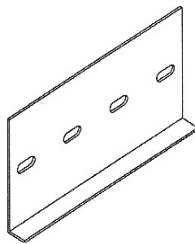

125(H)

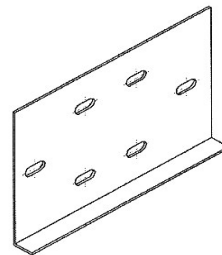

150(H)

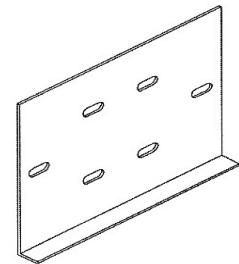

200(H)

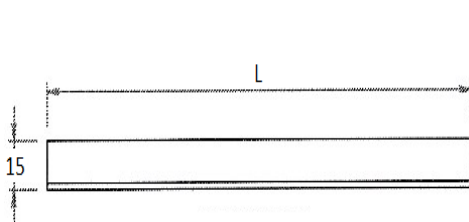

TOP VIEW

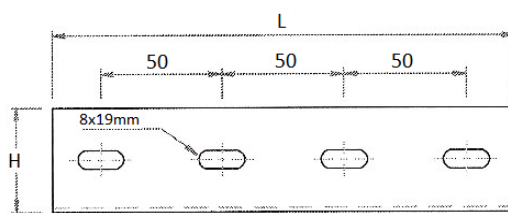

FRONT VIEW

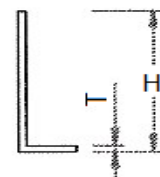

SIDE VIEW

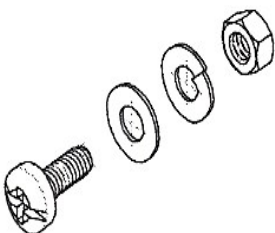

M6 X 20L Pan Head, Nut Flat & Spring Washer

STRAIGHT JOINT

HEIGHT TRAY	HEIGHT (H)	LENGTH (L)	THICKNESS (T)
100	94	150	1.5/2.0
125	119	200	2.0
150	144	200	2.0
200	194	200	2.0

*All units in mm

HORIZONTAL JOINT

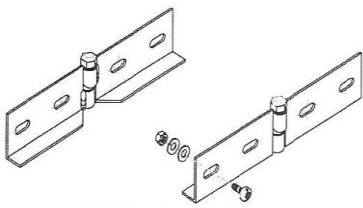
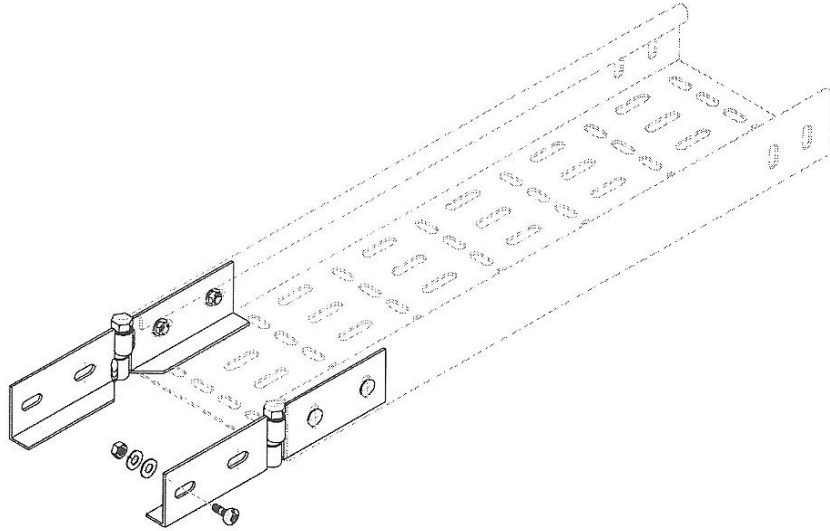

HORIZONTAL JOINT -100(H)

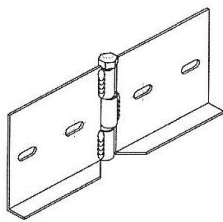

125(H)

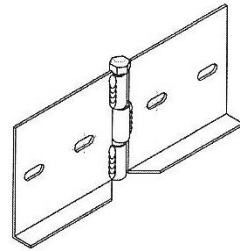

150(H)

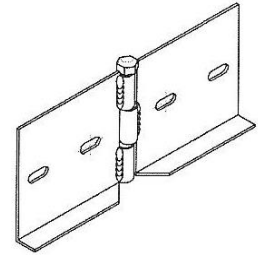

200(H)

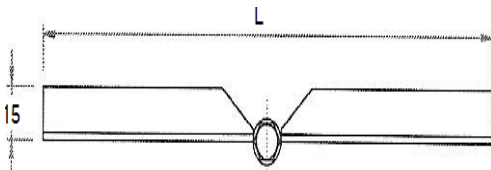

TOP VIEW

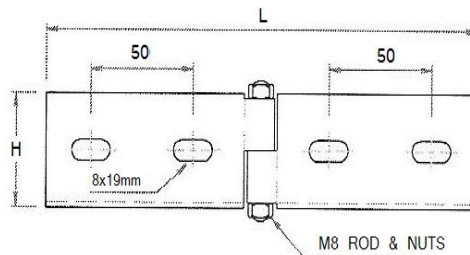

FRONT VIEW

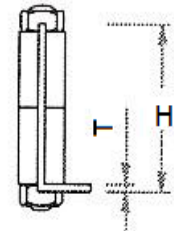

SIDE VIEW

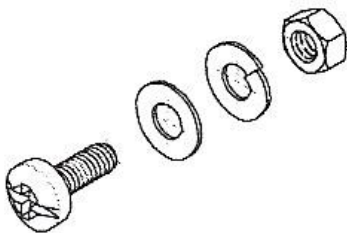

M6 x 20L Pan Head, Nut Flat & Spring Washer

HORIZONTAL JOINT			
HEIGHT TRAY	HEIGHT (H)	LENGTH (L)	THICKNESS (T)
100	94	150	1.5/2.0
125	119	200	2.0
150	144	200	2.0
200	194	200	2.0

*All units in mm

NOTE: Other sizes are available upon request

ASSEMBLE JOINT

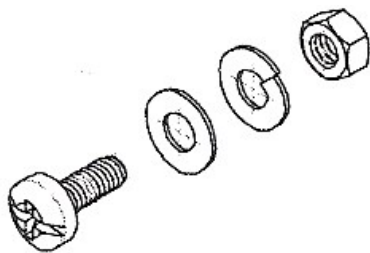
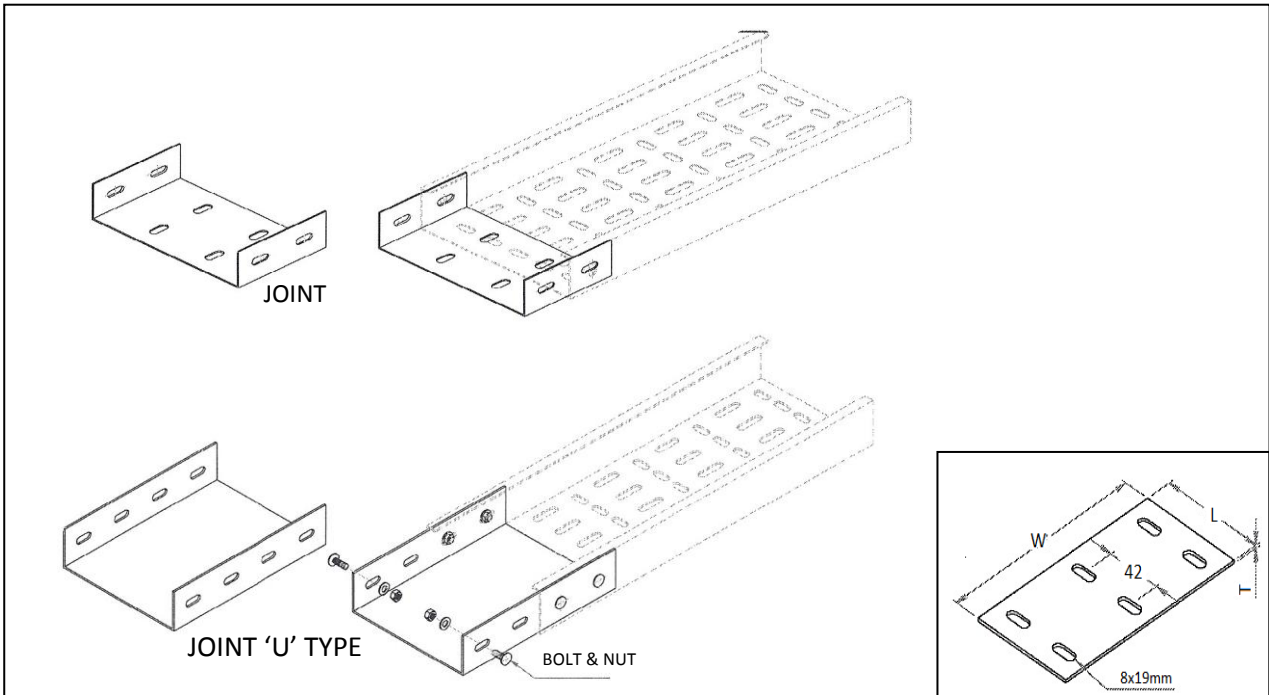
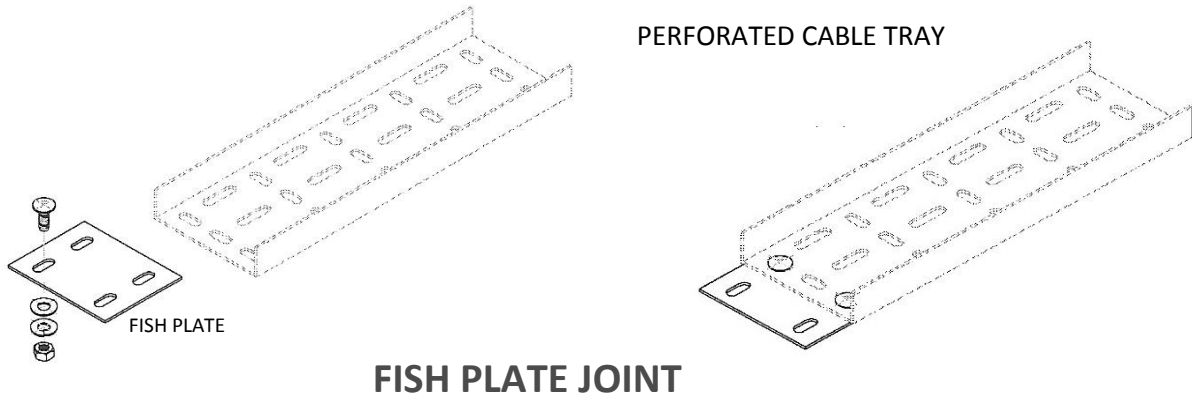

M6 x 20L Pan Head, Nut Flat & Spring Washer

HORIZONTAL JOINT			
HEIGHT TRAY	HEIGHT (H)	LENGTH (L)	THICKNESS (T)
100	94	150	1.5/2.0
125	119	200	2.0
150	144	200	2.0
200	194	200	2.0

*All units in mm

NOTE: Other sizes are available upon request

CABLE TRAY & ACCESSORIES

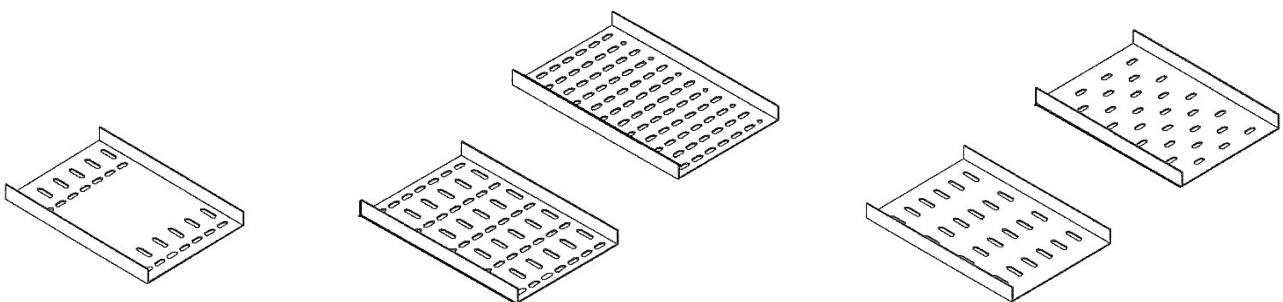
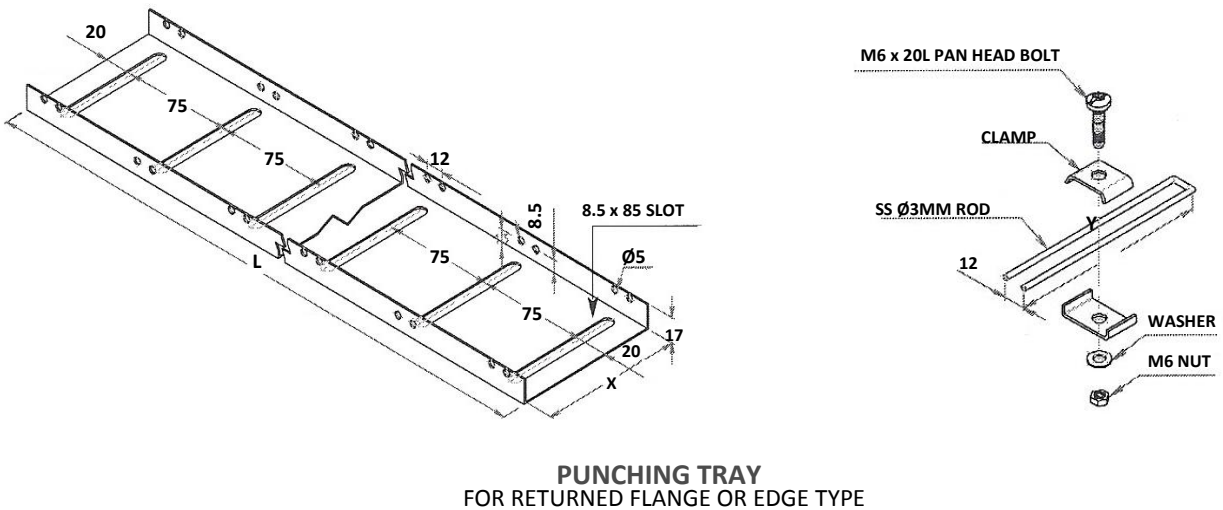
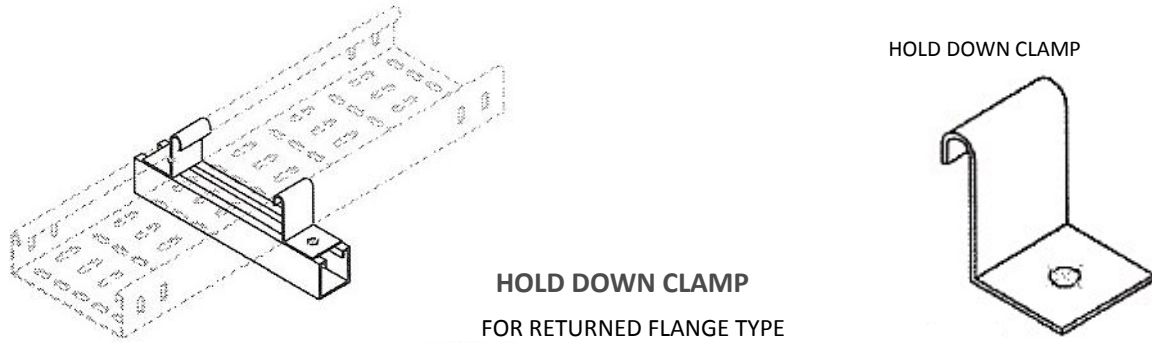
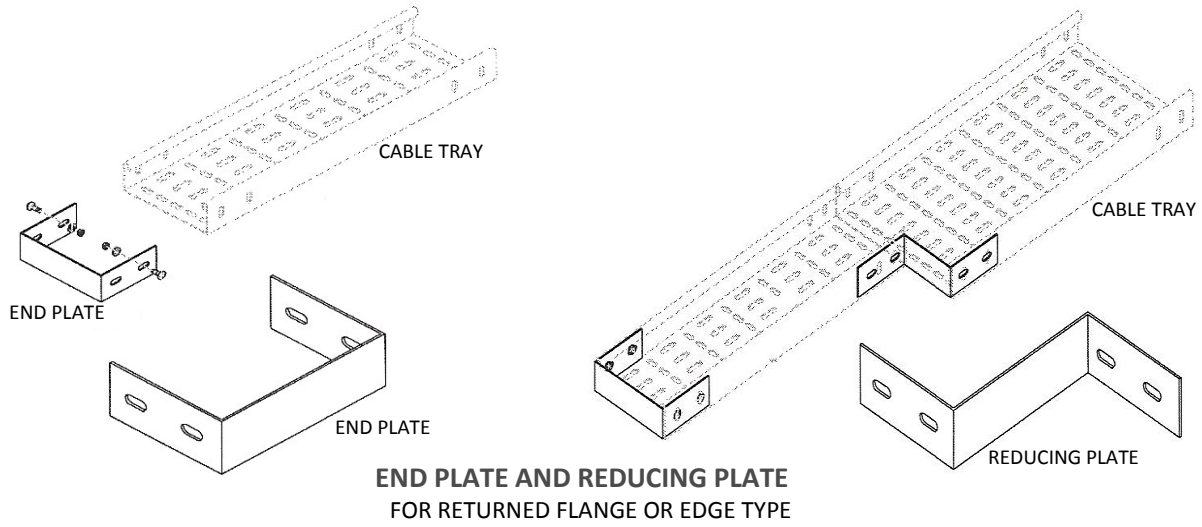

CABLE TRAY & ACCESSORIES

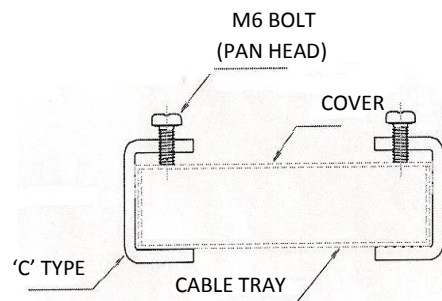
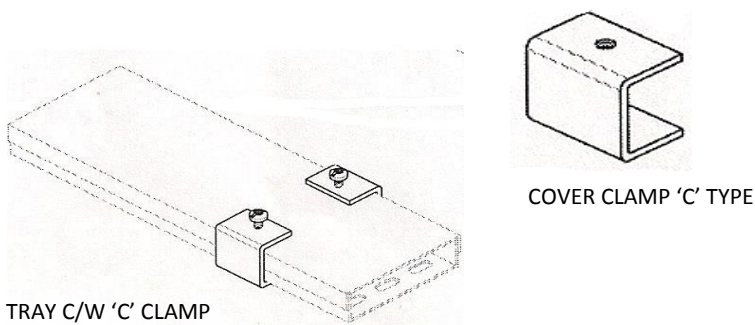
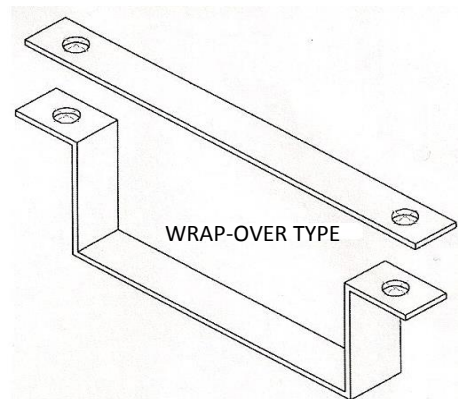
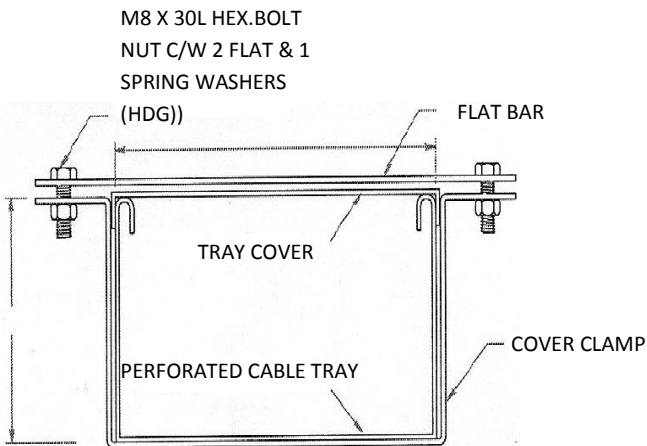
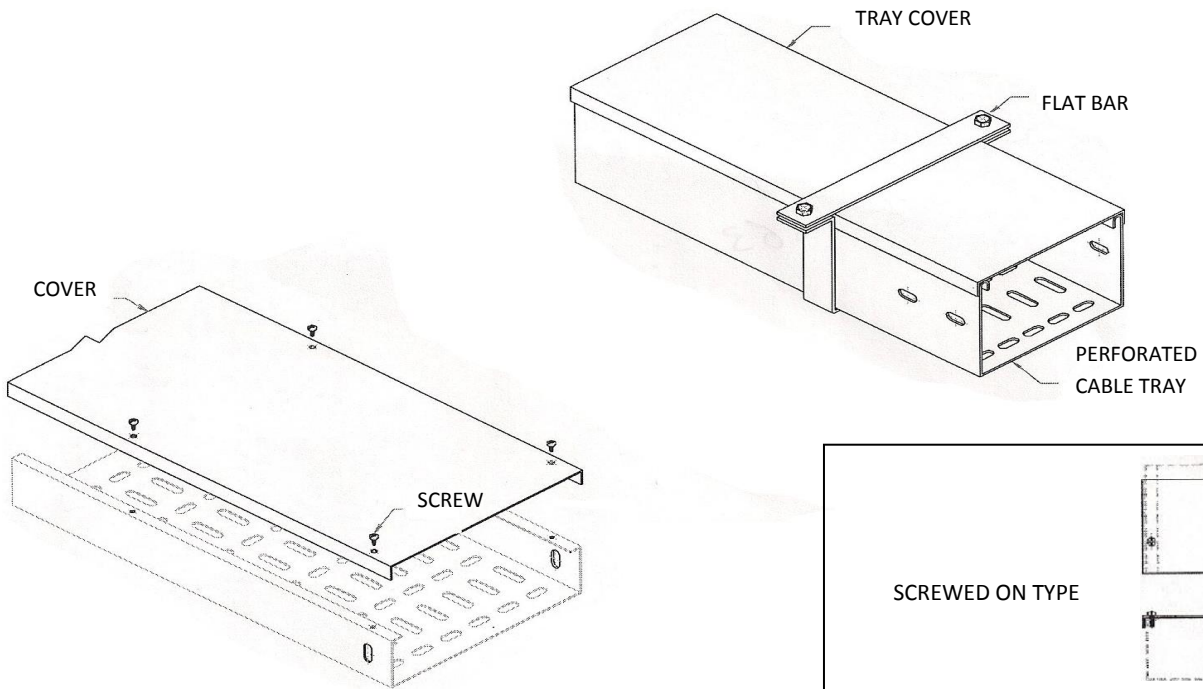

NOTE: HDG PUNCHING PLATE C/W COVER & 6 PCS OF COVER CLIP (C TYPE) WITH 6 PCS OF M6 X 12L PAN HEAD BOLT X 1 PC OF STRAIGHT FISH PLATE X 4 SETS OF SS M8 X 20L CARRIAGE BOLT, 1 FLAT WASHER & 1 SPRING WASHER

CABLE TRAY & ACCESSORIES

CABLE TRAY & COMPONENTS ASSEMBLY GUIDE

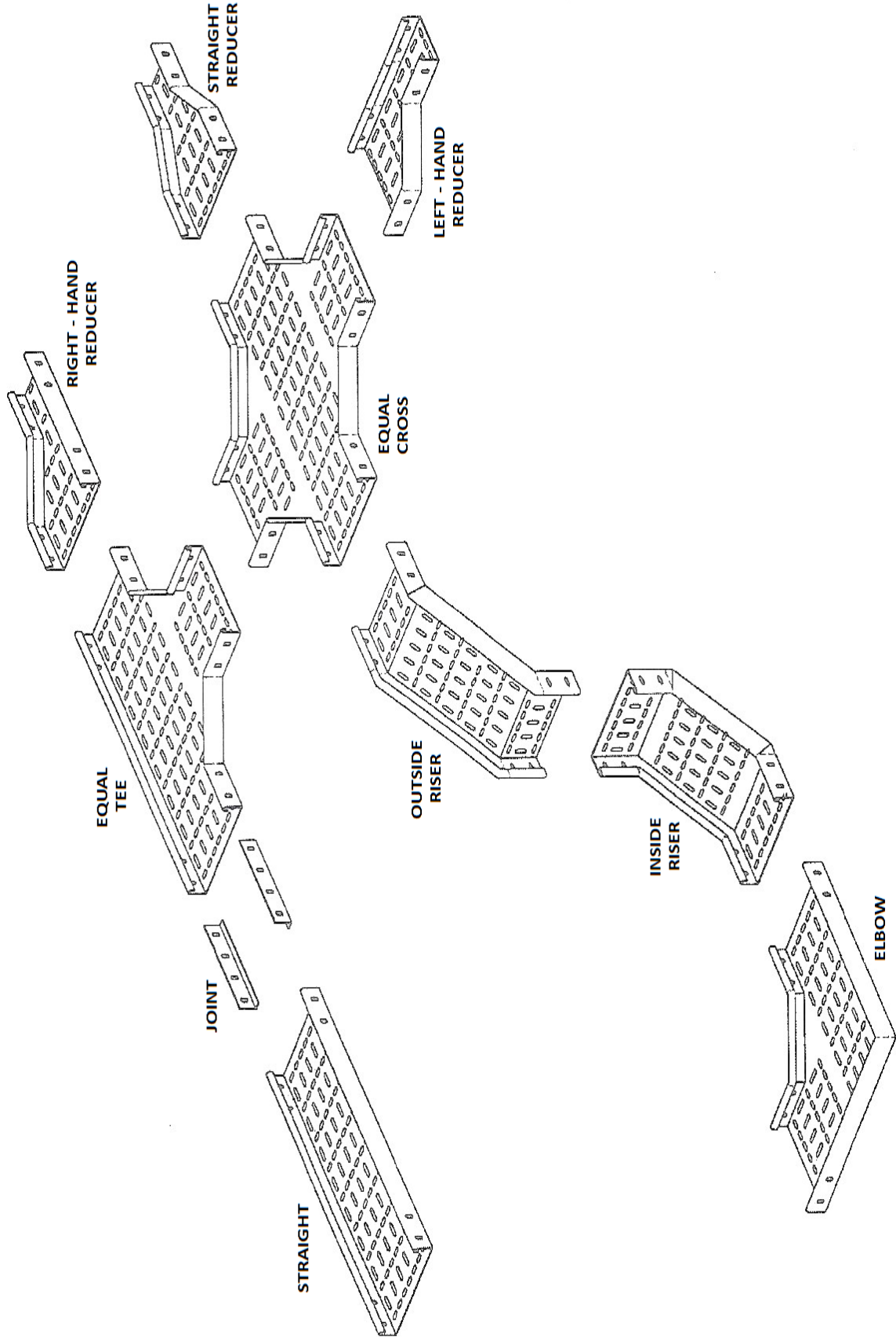

* A PREFABRICATED METAL STRUCTURE CONSISTING OF ONE PIECE BOX CHANNEL SECTION

CABLE TRAY & ACCESSORIES