



LEAD THE CHANGE

WATER HEATER & DECORATIVE
CEILING FANS 2015

20 Years of Innovation for A Better Future

RUBINE is one of the leading household appliances and fittings brands over the past 20 years with a wide range of products combining the very latest technology with innovative designs. Undeniably recognised as one of the fastest growing brands in Malaysia, RUBINE is a top multi-award winning brand that is popular nationwide. Our confidence in new technological innovations combined with our ergonomic design approach has enabled us to take the lead in the industry. Our dedication to high quality is demonstrated by our unique warranty offered on most of the RUBINE range of products. We invent for the future, for a better home with our high-quality and durable products. Let our innovation push the limits, let our excellence be witnessed by advanced, solidly built and reliable products.



20 Years of Leading The Change

RUBINE's Milestones

Innovation

Innovation is the crucial element of RUBINE and the critical guideline in the development of high-quality and durable products. At RUBINE, all products are designed by the ergonomic approach, incorporating the latest innovative technology to ensure our products not only perform at their best, but also reflect the trend towards a modern, better living environment.

Quality

Top quality, high functionality and irresistible elegance in the products, matched by our excellent service, are part of our 20-year tradition. Our aspiration is to be regarded as the "leader in the change (of new trend)". We promise you that our products will not only win you over, but also delight you.

Efficiency

We deploy groundbreaking technological innovations to develop the resource-efficient household appliances and fittings to create the potential to not only improve the future, but also our quality of life today. RUBINE's products are made with respect & sensitivity to the environment, that excel in terms of quality, innovative technology and energy efficiency.

2015

RUBINE is now the leading & popular home appliances and fittings brand nationwide. It widely recognized as one of the fastest growing brands in Malaysia, and continues inventing for a better home solution.

1979

FIAMMA SDN. BHD. the first company under FIAMMA HOLDINGS BERHAD group of companies begins operations in Johore Bahru. Later, our Kuala Lumpur office established, the site of our headquarters today.

1980

Our Penang branch opens. This marks the beginning of FIAMMA'S expansion throughout Peninsular & East Malaysia.

1995

FIAMMA HOLDINGS BERHAD is converted to a public company. FIAMMA TRADING SDN. BHD. is set up to distribute sanitary fittings, bathroom solutions and kitchen appliances.

1997

FIAMMA HOLDINGS BERHAD is successfully listed on the main board of Bursa Malaysia Securities.

2000

FIAMMA TRADING SDN. BHD. commenced the distribution of RUBINE brand in sanitary fittings, bathroom solutions and kitchen appliances.

2004

The group relocated to a new head office cum wholesale distribution center with automated retrieval system (ASRS) facilities in Bandar Manjalara, Kuala Lumpur.

2009

FIAMMA TRADING SDN. BHD. developed into the distribution of the ceiling fan and instant water heater.

2011

The brand RUBINE was awarded the Brilliant Star Awards for the Kitchen appliances category at the Kitchen+Bathroom Recognition Awards 2010/2011.



FEATURES

IA Intelligent Agent Series

Silent Performance with Lifesaving Protection



INSTANT WATER HEATER

1 INNOVATIVE AUTO INSPECTION ALARM

With added safety functionality built in, the water heater will check and detect different types of errors and malfunctions. In the event an error is found during the installation process or in the appliance itself, an alarm will go off to warn users of the potential danger.

60% ECO-FRIENDLY INVERTER TECHNOLOGY

Enjoy up to an astounding 60% of energy savings with the eco-friendly technology of Inverter Silent Pump, as compared to regular Booster Pump models.

EXTRA DPDT SAFETY EXTRA SAFE DPDT PROTECTION SYSTEM

With your family's safety in mind, RUBINE has engineered cutting-edge innovations for the home with double pole reply, double thermostat cut-off protection system.

BUILT-IN AUTO WATER FLOW SWITCH

SPLASH PROOF PROTECTION (IP25 STANDARD)

UL-APPROVED HIGH-QUALITY HEATING ELEMENT TECHNOLOGY FROM UK

3-IN-1 COMPACT STOP, FLOW & FILTER VALVE



auto inspection alarm



- 10yrs Warranty ON ANTI-TANK LEAKAGE
- 7yrs Warranty ON HEATING ELEMENT
- 1yr Warranty ON INTENAL PARTS
- 5yrs Warranty ON INVERTER SILENT PUMP

IA INVERTER SILENT PUMP & BOOSTER PUMP SERIES

INSTANT WATER HEATER



IA INVERTER SILENT PUMP (DC)

WITH RAIN SHOWER SET

Classic Gold	~ RWH-IA951D-RCG	(9555301210425)
Modern White	~ RWH-IA951D-RMW	(9555301210449)
Metallic Grey	~ RWH-IA951D-RMG	(9555301210432)
Silvered Titanium	~ RWH-IA951D-RST	(9555301210456)

WITH CHROMED ACCESSORIES

Classic Gold	~ RWH-IA951D-CCG	(9555301210463)
Modern White	~ RWH-IA951D-CMW	(9555301210487)
Metallic Grey	~ RWH-IA951D-CMG	(9555301210470)
Silvered Titanium	~ RWH-IA951D-CST	(9555301210494)

IA BOOSTER PUMP (AC)

WITH RAIN SHOWER SET

Classic Gold	~ RWH-IA952A-RCG	(9555301210500)
Modern White	~ RWH-IA952A-RMW	(9555301210524)
Metallic Grey	~ RWH-IA952A-RMG	(9555301210517)
Silvered Titanium	~ RWH-IA952A-RST	(9555301210531)

WITH CHROMED ACCESSORIES

Classic Gold	~ RWH-IA952A-CCG	(9555301210548)
Modern White	~ RWH-IA952A-CMW	(9555301210562)
Metallic Grey	~ RWH-IA952A-CMG	(9555301210555)
Silvered Titanium	~ RWH-IA952A-CST	(9555301210579)

PRODUCT TYPE

Power Rating
Minimum Working Pressure
Inlet / Outlet Water Connector
Temperature Control
Pump Type
Noise Level
Product Dimension WxDxH
Product Weight

IA INVERTER SILENT PUMP (DC)

3.6kW 240V 50Hz
0.2 Bar
Ø15mm (½"BSP)
Stepless Electronic
Inverter Silent Pump
<45db
225 x 75 x 375 (mm)
1.8kg

IA BOOSTER PUMP (AC)

3.6kW 240V 50Hz
0.2 Bar
Ø15mm (½"BSP)
Stepless Electronic
Booster Pump
<60db
225 x 75 x 375 (mm)
2kg

IA NON-PUMP SERIES



Modern White (MW)

Metallic Grey (MG)

Silvered Titanium (ST)



CHROMED ACCESSORIES

INSTANT WATER HEATER

IA NON PUMP

WITH CHROMED ACCESSORIES

Modern White	~ RWH-IA950N-CMW	(9555301210593)
Metallic Grey	~ RWH-IA950N-CMG	(9555301210586)
Silvered Titanium	~ RWH-IA950N-CST	(9555301210609)

PRODUCT TYPE	Power Rating
Minimum Working Pressure	Inlet / Outlet Water Connector
Temperature Control	Pump Type
Noise Level	Product Dimension WxDxH
Product Weight	

IA NON PUMP	3.6kW 240V 50Hz
0.2 Bar	Ø15mm (½" BSP)
Stepless Electronic	N/A
N/A	N/A
225 x 75 x 375 (mm)	1.3kg

Auto Inspection Alarm Indication

Applicable for all IA models

ALARM 1	ALARM 2	ALARM 3	ALARM 4
GOOD & SAFE	TRIPPED ELCB	ELCB SENSOR MALFUNCTION	EARTH WIRE ERROR
LIGHT 	LIGHT 	LIGHT 	LIGHT
BEEP 	BEEP 	BEEP 	BEEP
LIGHT 	LIGHT 	LIGHT 	LIGHT
BEEP 	BEEP 	BEEP 	BEEP
Could be water tank leakage or internal parts malfunction! Contact professional technician immediately.	Could be ELCB Sensor malfunction! Contact professional technician immediately.	Could be EARTH wire connection error! Contact professional technician immediately.	

FEATURES

SSE Series

Smart. Slim. Elegant.

INSTANT WATER HEATER



SLIM & ELEGANT DESIGN

The SSE comes in a 190mm width slim profile with a beautiful curvy design. An aesthetically pleasing addition to any beautifully crafted bathroom.



60% ECO-FRIENDLY INVERTER TECHNOLOGY

Enjoy up to an astounding 60% of energy savings with the eco-friendly technology of Inverter Silent Pump, as compared to regular Booster Pump models.



EXTRA SAFE DPDT PROTECTION SYSTEM

With your family's safety in mind, RUBINE has engineered cutting-edge innovations for the home with double pole reply, double thermostat cut-off protection system.



BUILT-IN AUTO WATER FLOW SWITCH



SPLASH PROOF PROTECTION (IP25 STANDARD)



UL-APPROVED HIGH-QUALITY HEATING ELEMENT TECHNOLOGY FROM UK



3-IN-1 COMPACT STOP, FLOW & FILTER VALVE

10 yrs Warranty ON ANTI-TANK LEAKAGE

7 yrs Warranty ON HEATING ELEMENT

1 yr Warranty ON INTERNAL PARTS

5 yrs Warranty ON INVERTER SILENT PUMP

SSE INVERTER SILENT & BOOSTER PUMP SERIES



INSTANT WATER HEATER

SSE INVERTER SILENT PUMP (DC)

WITH RAIN SHOWER SET

Classic Gold	~ RWH-SSE851D-RCG	(9555301210616)
Modern White	~ RWH-SSE851D-RMW	(9555301210630)
Metallic Grey	~ RWH-SSE851D-RMG	(9555301210623)
Silvered Titanium	~ RWH-SSE851D-RST	(9555301210647)
Carbon Black	~ RWH-SSE851D-RCB	(9555301210654)

WITH CHROMED ACCESSORIES

Metallic Grey	~ RWH-SSE851D-CMG	(9555301210661)
Silvered Titanium	~ RWH-SSE851D-CST	(9555301210678)

WITH WHITE ACCESSORIES

Modern White	~ RWH-SSE851D-WMW	(9555301210685)
--------------	-------------------	-----------------

SSE BOOSTER PUMP (AC)

WITH RAIN SHOWER SET

Classic Gold	~ RWH-SSE852A-RCG	(9555301210692)
Modern White	~ RWH-SSE852A-RMW	(9555301210715)
Metallic Grey	~ RWH-SSE852A-RMG	(9555301210708)
Silvered Titanium	~ RWH-SSE852A-RST	(9555301210722)
Carbon Black	~ RWH-SSE852A-RCB	(9555301210739)

WITH CHROMED ACCESSORIES

Metallic Grey	~ RWH-SSE852A-CMG	(9555301210746)
Silvered Titanium	~ RWH-SSE852A-CST	(9555301210753)

WITH WHITE ACCESSORIES

Modern White	~ RWH-SSE852A-WMW	(9555301210760)
--------------	-------------------	-----------------

PRODUCT TYPE

Power Rating
Minimum Working Pressure
Inlet / Outlet Water Connector
Temperature Control
Pump Type
Noise Level
Product Dimension WxDxH
Product Weight

SSE INVERTER SILENT PUMP (DC)

3.6kW 240V 50Hz
0.2 Bar
Ø15mm (½"BSP)
Stepless Electronic
Inverter Silent Pump
45db
190 x 75 x 440 (mm)
1.8kg

SSE BOOSTER PUMP (AC)

3.6kW 240V 50Hz
0.2 Bar
Ø15mm (½"BSP)
Stepless Electronic
Booster Pump
<60db
190 x 75 x 440 (mm)
2kg

SSE NON PUMP SERIES

INSTANT WATER HEATER

CHROMED ACCESSORIES



Metallic Grey (MG)

WHITE ACCESSORIES



Modern White (MW)

SSE NON PUMP

WITH CHROMED ACCESSORIES

Metallic Grey ~ RWH-SSE850N-CMG (9555301210777)

WITH WHITE ACCESSORIES

Modern White ~ RWH-SSE850N-WMW (9555301210784)

PRODUCT TYPE

Power Rating
Minimum Working Pressure
Inlet / Outlet Water Connector
Temperature Control
Pump Type
Noise Level
Product Dimension WxDxH
Product Weight

SSE NON PUMP

3.6kW 240V 50Hz
0.2 Bar
Ø15mm (½"BSP)
Stepless Electronic
N/A
N/A
190 x 75 x 440 (mm)
1.3kg

PRODUCT DIMENSIONS

RAIN SHOWER SET

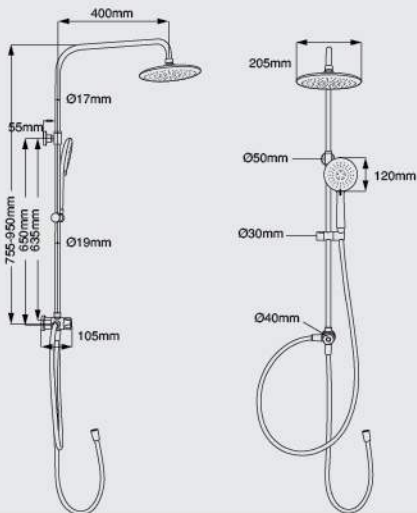

CHROMED ACCESSORIES

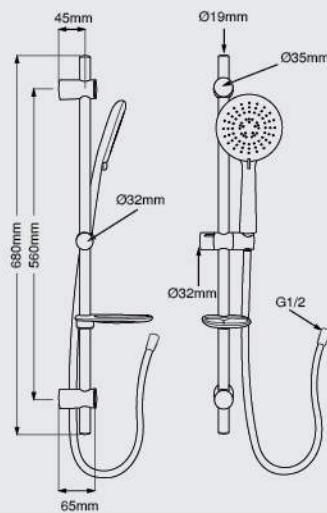

WHITE ACCESSORIES

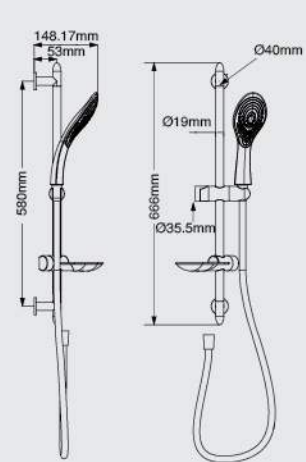

Exposed Rain Shower Set

5E Features



INSTANT WATER HEATER

50% **ECO WATER SAVING UP TO 50%**

Two Water Saver Chips (in the rain shower and the hand shower) maintain the water flow rate within a suitable level at any water pressure, hence helping you to save water up to 50%.

ENJOYABLE SOOTHING SENSATION

To ensure that you have a soothing and relaxing shower, RUBINE has specially designed the slim rain shower with the diameter of 205mm and the extra wide 120mm hand shower.

360° EXHILARATING 360° ROTATING DIVERTER SHOWER

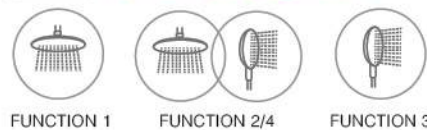

FUNCTION 1 FUNCTION 2/4 FUNCTION 3

EXTRA DURABLE TUBE CONNECTOR

Tube connectors are equipped with Triple O-Rings to ensure extra durability. As such, they can withstand a higher water pressure to prevent water leak.

EFFECTIVE ANTI-TWIST FLEXIBLE HOSE

The anti-twist hose prevents any loops or knots regardless of how many times the showerhead is twisted around.

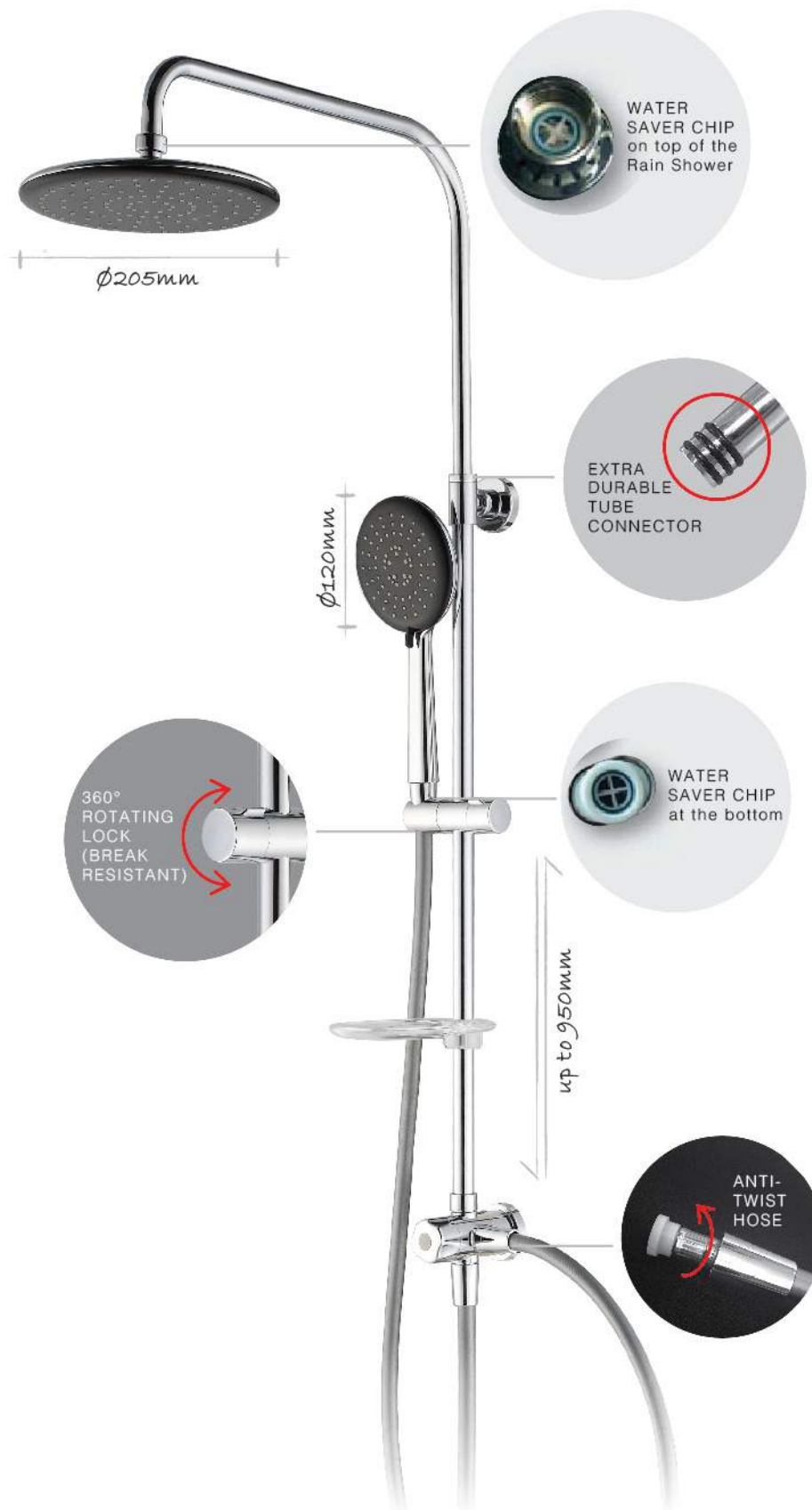









MAINTENANCE TIPS

For smooth flow & purified water, wash the Stop Valve Filter (a), and Hose Filter (b) thoroughly every month or when necessary.

Our Warranty & Recognition

Instant Water Heater

 10 yrs Warranty	 7 yrs Warranty	 SIRIM TESTED ST APPROVED	 TESTED TISI APPROVED
ON ANTI-TANK LEAKAGE	ON HEATING ELEMENT	MALAYSIA'S RECOGNITION	THAILAND'S RECOGNITION
 1 yr Warranty	 5 yrs Warranty	 TESTED SPRING APPROVED	 HEATING ELEMENT ONLY
ON INTENAL PARTS	ON INVERTER SILENT PUMP	SINGAPORE'S RECOGNITION	CANADA/ USA'S RECOGNITION

Decorative Ceiling Fan

 10 yrs Warranty	 SIRIM TESTED
ON POWERFUL QUIET MOTOR	SIRIM TESTED CERTIFIED TO: MS IEC 60335-1:2005 MS 1597: Part 2-80:2010 MS 1220:2010 CERTIFICATION NO: PC001507
	 ST APPROVED ENERGY CONSUMPTION

 6 mths Warranty Extension	6-months Warranty Extension When Register Online!
---	--

- Online Registration**
1. Log on to www.rubine.com.my
 2. Click on 'Support', followed by 'Warranty'. Then, click on 'Warranty Registration' to proceed. You're required to sign up as a member.
 3. Please fill up the necessary information, tick on the checkbox and click 'Next'.
 4. You'll receive a notification of warranty registration confirmation via email.
 5. Your warranty will be automatically extended for another 6 months upon registration online. Please keep your online warranty certificate for reference.



Customer Care

AFTER-SALES SERVICE:
 Exact Quality Sdn. Bhd.
 Hotline: **1800-282-093**
 Email: **eqservice@fiamma.com.my**

CUSTOMER CARE:
 For further inquiries, kindly visit our website at **rubine.com.my**

OPERATION HOURS
08:30am - 06:00pm
 (Monday - Friday, except public holiday)

*Features highlighted are applicable for selected models only. Product specifications subject to change without prior notice. Actual product may different slightly from picture shown.



LEAD THE CHANGE

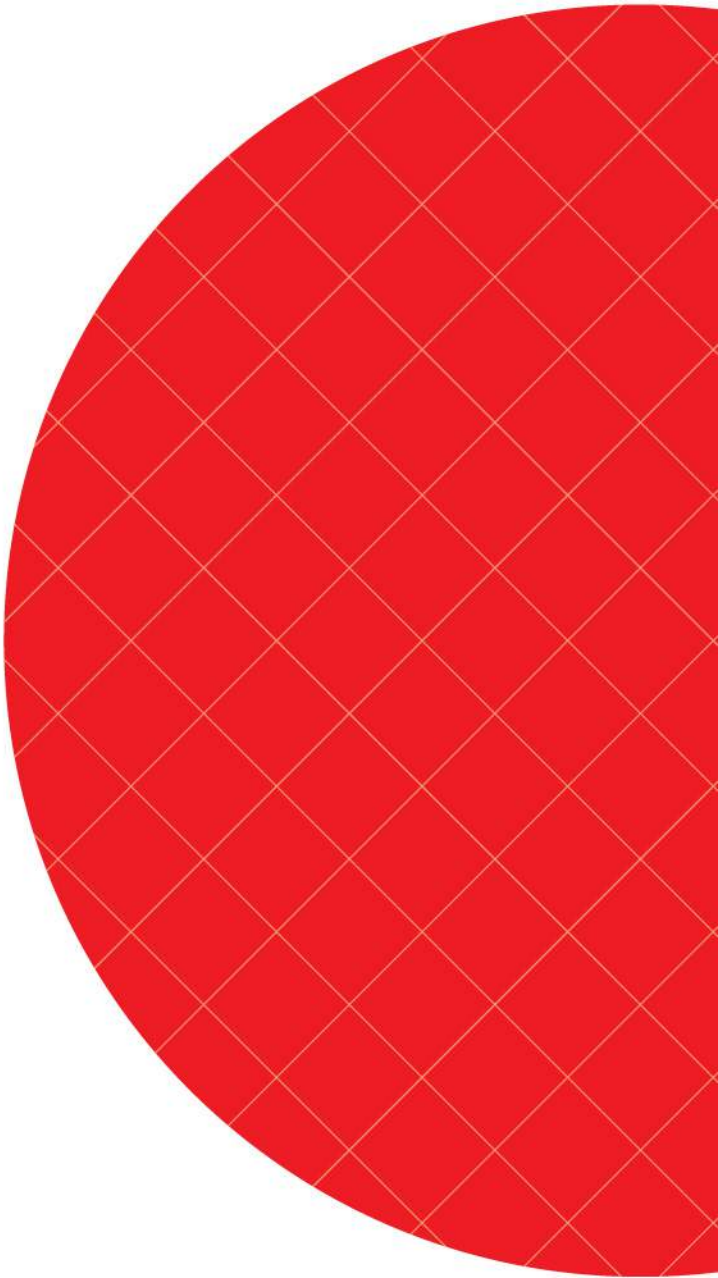

rubine.com.my



FIAMMA TRADING SDN BHD 330476-P (A member of Fiamma Holdings Berhad)
9-2, Wisma Fiamma, No.20, Jalan 7A/62A, Bandar Manjalara, 52200 Kuala Lumpur. Tel: 03-6279 8943

AUTHORIZED DEALER

